

MANUALE ISTRUZIONI
OPERATOR'S HANDBOOK
MANUEL D'UTILISATION
GEBRAUCHSANWEISUNG
MANUAL DE INSTRUCCIONES

**TURBO
SMART**
A UNIVERSAL ASPIRATOR

C
CATTANI
AIR TECHNOLOGY



TURBO SMART

A UNIVERSAL ASPIRATOR

INDICE

Dati generali di funzionamento 50/60 Hz	2
Introduzione	3
Segnali ed avvisi	3
Montaggio e messa in funzione	4
Manutenzione ordinaria	8
Manutenzione straordinaria	9
Istruzioni per muoversi e modificare alcuni parametri nei menù di Turbo-Smart	10
Istruzioni per settare la comunicazione Zig-bee (wireless)	17
Descrizione allarmi	22
Avvisi importanti	23
Trasporto e stoccaggio	23
Trasporto di apparecchi usati	23
Illustrazioni.....	121

- *Dati generali di funzionamento 50/60 Hz Aspiratore ad uso dentistico Turbo-Smart*

Modello	Turbo-Smart "A"		Turbo-Smart "B"	
Tensione nominale	230 V ~		230 V ~	
Frequenza nominale	50/60 Hz		50/60 Hz	
Corrente nominale	7 A		9 A	
Modalità di impiego	Funzionamento continuo		Funzionamento continuo	
Protezione contro l'umidità	Comune		Comune	
Potenza massima assorbita	1,45 kW		1,87 kW	
Portata massima	86 m ³ /h		105 m ³ /h	
Prevalenza massima per il servizio continuo	2000 mm H ₂ O		2000 mm H ₂ O	
Velocità di rotazione	70 hz	85 hz	70 hz	110 hz
Pressione sonora versione scarenata	68,4 dB(A)	69 dB(A)	68,4 dB(A)	73,7 dB(A)
Pressione sonora versione carenata in plastica	66,4 dB(A)	67 dB(A)	66,4 dB(A)	72 dB(A)
Pressione sonora versione carenata per interno	48,5 dB(A)	49,5 dB(A)	48,5 dB(A)	52,2 dB(A)
Pressione sonora versione carenata per esterno	54 dB(A)	55 dB(A)	54 dB(A)	58,7 dB(A)

~	Corrente alternata	IEC 417-5032
⊕	Terra di protezione	IEC 417-5019
	Grado di protezione contro i contatti diretti o indiretti	IEC 60204-1
○	Aperto (sconnessione dalla rete di alimentazione)	IEC 417-5008
I	Chiuso (connessione alla rete di alimentazione)	IEC 417-5007

Livello di pressione sonora rilevato secondo la norma ISO 3746-1979 (E).
 Parametri: r = 1,5 - rumore di fondo: 34 dB(A) - strumento Bruel & Kjaer type 2232.

- *Introduzione*
- *Segnali ed avvisi*

- **Introduzione**

La presentazione che segue ha lo scopo di illustrare il montaggio e la messa in funzione di Turbo-Smart, e di informare circa i pericoli e le precauzioni utili alla prevenzione.

Il presente manuale deve essere sempre disponibile per essere consultato durante il disimballaggio, l'uso, il montaggio e la messa in funzione del Vostro aspiratore Turbo-Smart.

Nel sito Internet **www.cattani.it** sono rintracciabili i nostri manuali **aggiornati**.

Ne consigliamo la consultazione specialmente per gli aggiornamenti sulla **sicurezza**.

- **Segnali ed avvisi**

- *Pericolo di scosse elettriche, anche la 230 V \sim può risultare mortale.*



- *Pericolo biologico, infezioni da malattie epidemiche.*



- *Segnale generico di pericolo.*



- *Protezioni personali per lavori pesanti.*



- *Protezioni personali per pericolo biologico.*



- *Alta temperatura.*



- *Locale interdetto a sostanze infiammabili, corrosive od esplosive.*



- *Direzione obbligatoria del flusso o del senso di rotazione.*



Non sempre è possibile esprimere con un segnale gli avvisi di pericolo, è perciò necessario che l'utilizzatore legga gli avvisi e li tenga in debito conto.

Non rispettare un segnale od un avviso di pericolo, può causare danno all'operatore od al paziente.

Non rimuovere le protezioni antinfortunistiche, non modificare le macchine od il loro funzionamento.

Nonostante il nostro impegno è possibile che gli avvisi di pericolo non siano esaustivi, chiediamo venia all'utilizzatore, pregandolo nel contempo di prevedere egli stesso le fonti di pericolo che ci fossero sfuggite e darcene notizia.

• *Montaggio e messa in funzione*

• *Precauzioni raccomandate*

Prima di disimballare l'apparecchio, controllare l'esterno dell'imballo, fare attenzione all'indicatore di urti, trovando l'indicatore rosso, od il cartone danneggiato, accettarlo con riserva di controllare l'apparecchio.

Togliere la macchina dal cartone seguendo le istruzioni riportate all'esterno dell'imballo. Il cartone è riciclabile, si raccomanda di smaltirlo conformemente alle norme vigenti. Conservare i tappi che chiudono tutte le comunicazioni, esterno/interno dell'apparecchio, potranno essere utili nel caso si dovesse spostare l'aspiratore.

Il montaggio dell'apparecchio deve essere eseguito da persona esperta ed attrezzata. L'aspiratore deve essere posizionato in ambiente pulito, lontano da fonti di calore, dall'umidità e dalla polvere. Nei montaggi esterni: balconi, verande e giardini, proteggere le macchine dalla pioggia, dagli spruzzi, dall'umidità, dal gelo e dall'esposizione diretta ai raggi del sole.

Segnaliamo in proposito la carenatura per esterni di Turbo-Smart completa di: doppio tetto isolante, impianto antigelo ed impianto di ventilazione, entrambi con termostato fisso per la regolazione automatica della temperatura.

La temperatura ambiente del locale tecnico non deve essere inferiore ai + 5 °C e non deve essere superiore ai + 35 °C.

Le macchine carenate, per interno e per esterno, possono essere ordinate complete di impianto antigelo. Dove fosse necessario ventilare o condizionare la sala macchine, è consigliabile far progettare l'impianto di ventilazione o di condizionamento da un termotecnico. Il locale tecnico non deve essere accessibile ai pazienti od ai passanti. Quando non sia disponibile tale locale è necessario che le macchine siano protette da una carenatura non facilmente asportabile. Predisporre protezioni e cartelli indicatori di pericolo, in modo da evitare contatti accidentali, pericolosi per le scosse elettriche, e per la possibilità (remota ma non escludibile) d'incendio, di scoppio, per la fuoriuscita di aria e di liquidi contaminanti. Servirsi esclusivamente di carenature (per interni e per esterni) studiate e costruite dal fabbricante.

Nel locale tecnologico non deve sostare materiale infiammabile, verificare che non vi sia la possibilità di fughe di gas. Non si debbono allacciare alla rete elettrica apparecchi danneggiati; non utilizzare prolunghe, prese o spine multiple. Prima di collegare l'apparecchio alla linea elettrica, controllare che questa sia conforme alle norme C.E.I. 64-8 e che sia presente un interruttore magnetotermico con differenziale (**16A**) in classe "A" o "B" secondo le norme EN 61008-1. I pavimenti di colore chiaro, in legno, linoleum, gomma o marmo, a contatto dei piedini antivibranti in gomma (**1**) possono cambiare colore e rimanere segnati; isolare perciò gli antivibranti dal pavimento con un foglio di plastica o di altro materiale adatto.

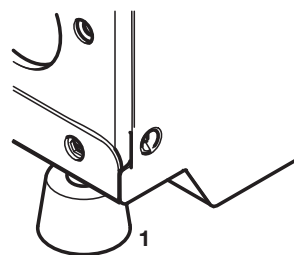
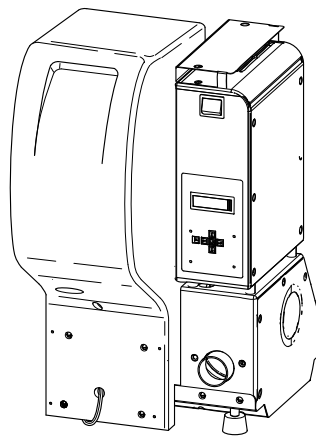
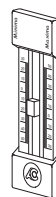
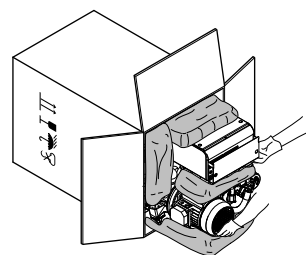

• Montaggio

Prima di collegare l'aspiratore alla canalizzazione dell'impianto centralizzato, accertarsi che le tubazioni aspiranti siano pulite, i detriti pesanti potrebbero danneggiare l'apparecchio. Il tubo di aspirazione (in PVC **(2b)** di colore grigio chiaro in dotazione all'apparecchio) deve essere collegato al portatubo **(2)** diametro 50 mm "ingresso fluido aspirato". Dalla parte opposta lo stesso tubo si collegherà alla canalizzazione aspirante **(3)** in arrivo dalle sale operatorie (pag. 6).

Il tubo per l'aria espulsa **(4b)** (di colore nero, resistente alla temperatura, con spirale metallica) deve essere collegato al portatubo **(4)** diametro 50 mm "uscita aria espulsa", l'altra estremità del tubo verrà collegata al filtro antibatterico **(5)** passando preferibilmente attraverso un silenziatore **(5a)** sempre in dotazione all'aspiratore. All'uscita dal filtro antibatterico, l'aria espulsa ancora calda, dovrà essere convogliata all'esterno. Il portatubo **(6)**, diametro 18 mm andrà collegato al tubo di scarico dei liquidi, si consideri che quando è presente l'Idrociclone l'aspiratore drena per caduta e che in nessun caso può scaricare verso l'alto. Il portatubo **(8)** diametro 10 mm "scarico d'emergenza" deve essere collegato al tubo di scarico liquidi. I tubi di collegamento che uniscono la macchina all'impianto di aspirazione e di drenaggio sono flessibili per ammortizzare le piccole vibrazioni indotte dal funzionamento dell'aspiratore. La canalizzazione aspirante corre generalmente nel pavimento, in prossimità dell'aspiratore sale per circa 30 cm sino a raggiungere il portatubo **(2)** (fig. A e B, pag. 121).

Anche quando Turbo-Smart è sistemato ad un piano inferiore rispetto agli studi, la canalizzazione aspirante deve scendere dalle sale operatorie al piano dell'aspiratore, compiere un percorso di qualche metro in piano sul pavimento e salire con un tubo flessibile sino al separatore centrifugo (fig. B, pag. 121), il fluido aspirato verrà risucchiato dall'aspiratore.

Terminato il montaggio si dovrà collegare il cavo di alimentazione alla linea elettrica dell'ambiente secondo la normativa EN 61008-1. Da ultimo si collegherà la linea dei consensi a bassa tensione: dai morsetti 19 e 20 del circuito AC80-07 (fig. C "schema elettrico AC80-07", pag. 122) alla linea dei consensi **(12)** (particolare 12, pag.6 e Fig. F, pag. 125) che raggiunge con collegamenti in parallelo tutti i riuniti dello stesso impianto. Accertarsi che si tratti di un contatto pulito (non in tensione).

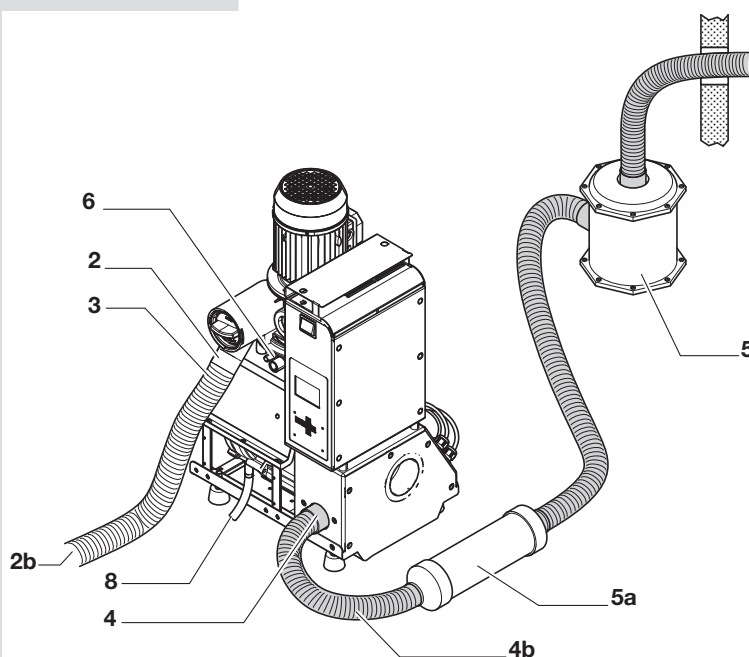
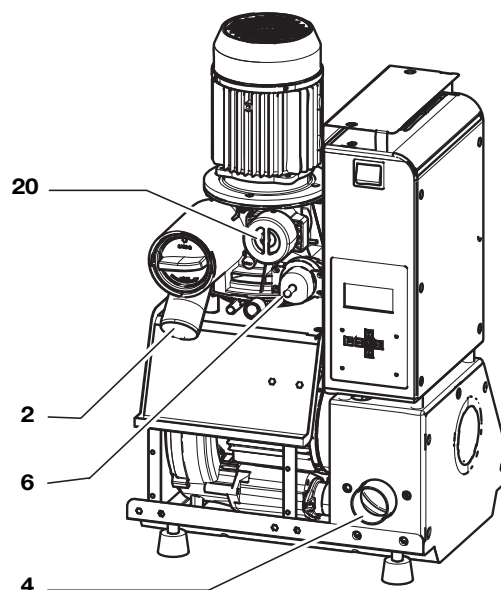

- **Montaggio in parallelo**

E' consigliabile montare in parallelo solo macchine uguali, con la stessa portata e la stessa prevalenza. Due o tre aspiratori in parallelo (fig. F) raddoppiano o triplicano la portata, a condizione che si aumenti di dieci millimetri il diametro della canalizzazione principale per ogni aspiratore che si aggiunge. Allo stesso modo si dovrà aumentare il diametro della canalizzazione dell'aria espulsa. Turbo-Smart è sempre completo di tutti gli accessori necessari al montaggio in parallelo, non sono quindi necessarie valvole unidirezionali, centralini supplementari o periferiche. Collegati alla stessa canalizzazione principale, i due o tre aspiratori in parallelo, si dovranno collegare in parallelo i consensi (12) in arrivo dai diversi riuniti. Mettendo in parallelo gli aspiratori, si dovrà fare attenzione a non invertire i cavetti dei morsetti n° 19 con quelli dei morsetti n° 20. Con più aspiratori in parallelo è possibile che un apparecchio si fermi senza che gli operatori se ne accorgano. Per ovviare a tale inconveniente, i morsetti 8 e 9 del centralino (contatto pulito) consentono di portare un segnale di allarme a distanza. I Turbo-Smart in parallelo funzionano meglio e offrono un maggior risparmio energetico, quando sono attivi contemporaneamente, indipendentemente dalla richiesta. Togliere corrente ad uno degli aspiratori non consente un risparmio energetico e diminuisce il rendimento degli aspiratori che rimangono in servizio.

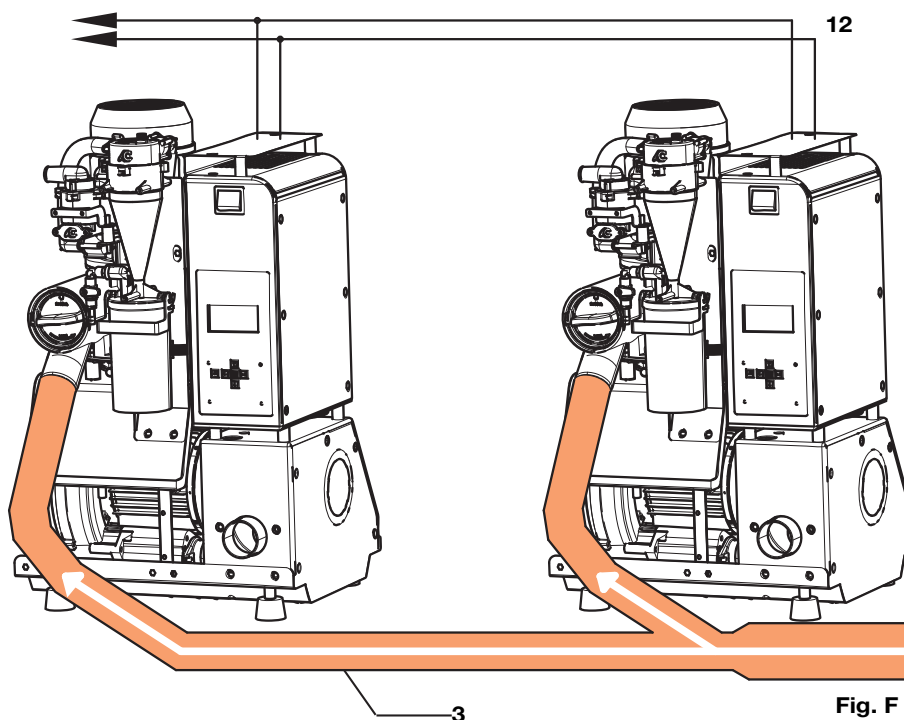

Fig. F

Draw. F

Messa in funzione, collaudo ed istruzione del personale

Una volta montato e collegato elettricamente l'aspiratore, basterà premere il pulsante acceso/spento e far partire il segnale del consenso da uno dei riuniti collegati, perché abbia inizio l'aspirazione.

Per verificare il corretto funzionamento dell'aspiratore Turbo-Smart, è consigliabile effettuare i test di tipo dinamico (esposti alla fig. D, pag. 123) ed il diagramma di lavoro di Turbo-Smart, fig. E pag. 124.

L'istruzione del personale per l'uso e la manutenzione ordinaria dell'aspiratore va fatta ad apparecchio nuovo non ancora contaminato.

Il personale dello studio deve essere istruito a seguire sul display le fasi di funzionamento di Turbo-Smart, ad interpretare gli avvisi di pericolo ed a fare una corretta manutenzione con Puli-Jet plus new con anticalcare **(A)**, Pulse Cleaner **(B)** e pastiglie antischiomogene disinfettanti **(C)**.

Funzionamento

Il gruppo aspirante **(9)** (attraverso il tubo **10**) crea la depressione nel separatore centrifugo **(11)**. Il fluido proveniente dagli studi, attraverso il tubo collettore **(2)** entra nel separatore centrifugo **(11)**.

Il separatore centrifugo separa l'aria dai liquidi: l'aria viene espulsa all'esterno attraverso il tubo **(4)** mentre i liquidi (in assenza del separatore di amalgama) vengono drenati in fognatura attraverso il tubo di scarico collegato al portatubo **(6)**.

La partenza del separatore centrifugo (part. **11**) è anticipata rispetto alla turbina (part. **9**), tale vantaggio consente di espellere i liquidi, eventualmente accumulati nel separatore centrifugo, prima che abbia inizio l'aspirazione. Inoltre allo spegnimento della macchina, un temporizzatore regolabile terrà in moto l'aspiratore da 10 a 120 secondi.

Il separatore di amalgama ISO 18

Turbo-Smart può essere ordinato completo del separatore di amalgama "Idrociclone ISO 18". Il separatore di amalgama è sempre accompagnato dal manuale di istruzione e manutenzione.

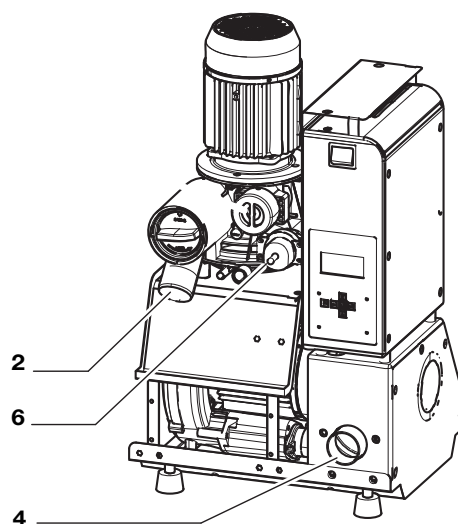
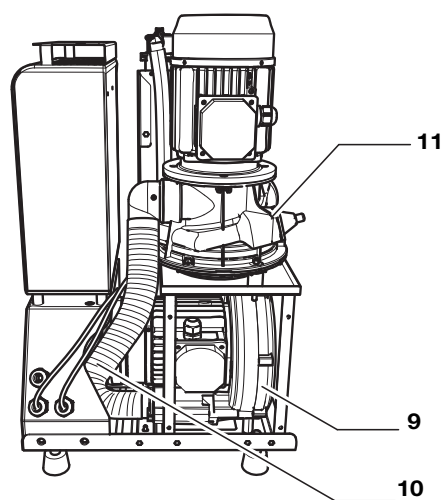
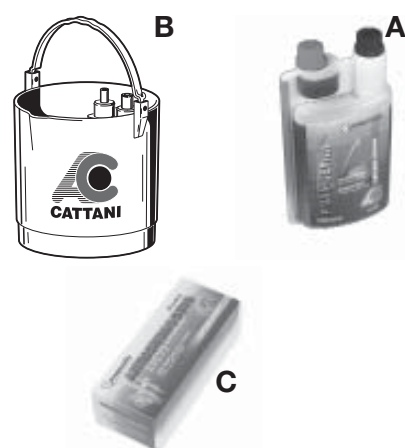

• *Manutenzione ordinaria*

La manutenzione ordinaria deve essere affidata al personale dello studio appositamente istruito.

- Si raccomanda di fare particolare attenzione a tutti i segnali di pericolo e di proteggersi con occhiali, guanti e grembiule monouso.

Ogni giorno

- Controllare sul display le eventuali segnalazioni di allarmi, in presenza di avvisi di pericolo mettersi in contatto con il tecnico.

Ogni sera

- Aspirazione serale di una soluzione di Puli-Jet plus new con anticalcare disinfettante **(A)** con Pulse Cleaner **(B)**;
- Prima di avvicinarsi all'aspiratore, togliere corrente.

Ogni giorno

- Posizionare le pastiglie antischiumogene nei filtri dei ri-uniti.

Periodicamente

- Tenere pulito il filtro dell'aspiratore.

Saltuariamente

- Controllare che non si formino ostacoli alla libera ventilazione dell'aspiratore;
- Tenere libero il locale tecnologico da quanto non attiene alle stesse macchine, con particolare riferimento a materiale infiammabile, sorvegliare che non vi sia la possibilità di formazione di miscele corrosive, infiammabili od esplosive.



ALLARME:
TEMPERATURA ELEVATA

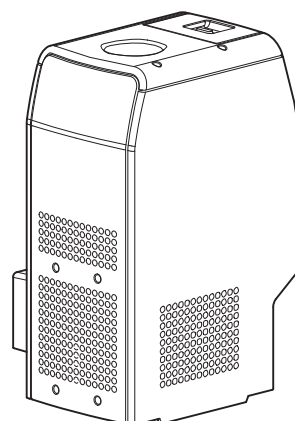
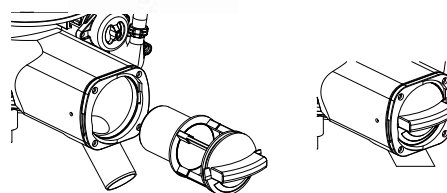
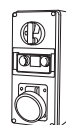
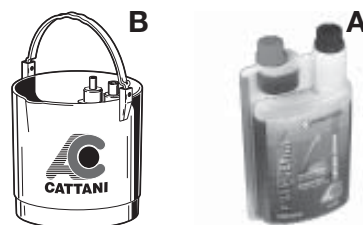

• Manutenzione straordinaria

La manutenzione straordinaria va affidata ad un tecnico preparato ed in possesso dei ricambi originali:

- Fare particolare attenzione a tutti i segnali di pericolo e proteggersi con occhiali, guanti e grembiule monouso.
- Controllare lo stato di manutenzione ordinaria, verificare che si usino prodotti Magnolia.
- Prima di intervenire sugli apparecchi fare alcuni lavaggi con Fast & Steril 3 (D), aspettare 15 minuti perché l'azione disinfettante abbia svolto il suo effetto.

Controlli consigliati ogni 12 mesi

- Controllare le temperature massime registrate e tutti i segnali di allarme, intervenire di conseguenza.
- Controllare la rumorosità dell'aspiratore, max.72 dB rilevati secondo la norma 3047(E).
- Con un getto d'aria asciutta che non superi la pressione di 2 bar, se necessario pulire i componenti elettronici del circuito AC80 e con una pressione di 6 bar pulire i forellini sul coperchio frontale del gruppo aspirante (15);
- Controllare i tubi in plastica, in modo particolare quelli in pressione (all'uscita del separatore centrifugo part. 11 e prima dell'Idrociclone ISO) dei quali consigliamo la sostituzione ogni 12-18 mesi.

Controlli consigliati ogni 18-24 mesi

- Controllare le condizioni di funzionamento del separatore centrifugo (11) e della valvola di ricircolo (14).

Controlli consigliati ogni 10.000 ore

- I particolari in gomma: OR, soffietti, tenute, vanno sostituiti ogni volta che si interviene smontando il particolare che interessa la tenuta.
- Sostituire i cuscinetti dei motori.
- In presenza di precaria manutenzione ordinaria o dell'uso di prodotti impropri, istruire il personale ed informare il responsabile dello studio.

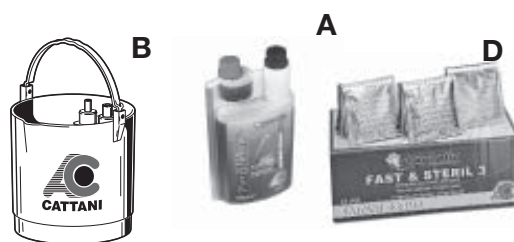

ALLARME:
TEMPERATURA ELEVATA

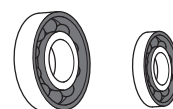
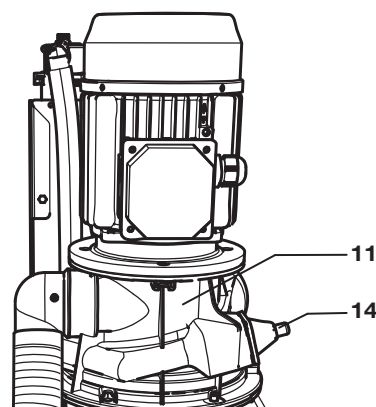
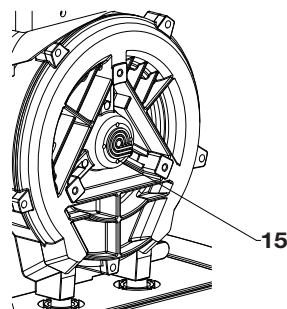

- *Istruzioni per muoversi e modificare alcuni parametri nei menù di Turbo-Smart*

Menù principali

All'accensione il display grafico mostra per 10 secondi il logo della Cattani S.p.A., al termine del quale apparirà il menù principale.



Menù principale "A1"

Sono visibili alcuni parametri come il livello di vuoto, il tempo di attivazione dell'aspiratore, la temperatura, il contenitore d'amalgama (se presente) e la revisione software del sistema.



Menù di controllo "A2"

Sono visibili: il numero di volte che Turbo-Smart è stato acceso, le ore di accensione totali, il numero di attivazioni dell'aspiratore, le ore effettive di utilizzo dell'aspiratore, la media delle ore di lavoro della sola soffiante e il numero di attivazioni del ventilatore.

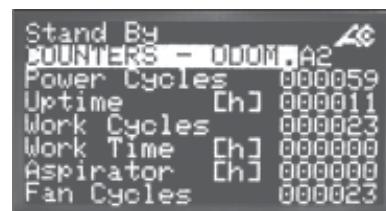

Menù degli eventi "A3"

Sono visibili gli ultimi 10 eventi o allarmi indicati da un numero, per decodificare l'evento vedere la tabella a pag. 22.



Menù di controllo "A2"

COUNTERS - ODOM . A2		
POWER CYCLES	000000	Numero di accensioni da interruttore generale
UPTIME [h]	000000	Ore totali di accensione
WORK CYCLES	000000	Numero di attivazioni da comando aspirazione
WORK TIME [h]	000000	Ore di lavoro effettive (motori in funzione)
ASPIRATOR [h]	000000	Ore medie di lavoro del motore d'aspirazione (Uni-Jet 75)
FAN CYCLES	000000	Numero di attivazioni della ventola di raffreddamento del centralino

Menù secondari

Premendo  si accede ai menù secondari.

Da questo menù si accede ai seguenti premendo la freccia. 

Drive Status

A questo menù si accede senza alcuna "Password", si possono qui visualizzare utili informazioni sul funzionamento di Turbo-Smart.

User Parameters

Si accede digitando la password "0000123000".

E' possibile modificare il livello di vuoto, la lingua ed inserire il "Codice di attivazione" per modificare da "A" a "B".

System Parameters Setup

Si accede digitando la password "0000456000".

E' possibile modificare il ritardo allo spegnimento ed altri parametri di tipo tecnico.

Factory Settings Restricted Access

Menù non accessibile, di esclusivo utilizzo dell'azienda Cattani.

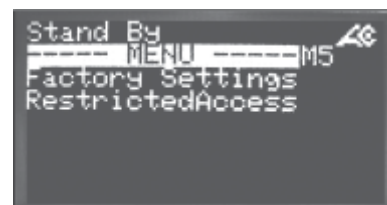
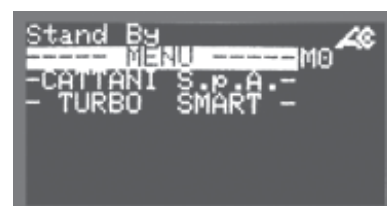



scroll down button
↓

Come entrare e digitare la "Password"

Drive Status è il solo menù consultabile senza l'utilizzo di alcuna "Password".

Per entrare nei menù "User Parameters" la "Password" di accesso è "0000123000".



Per entrare nei menù "System Parameters Setup" la "Password" di accesso è "0000456000".



Dal menù "CATTANI S.p.A.", premere la freccia  quindi la freccia  sul display apparirà il menù "Access Password" 0000000000

Premendo il tasto Enter  apparirà il cursore sullo 0 a destra.

Premendo  spostare il cursore sul sesto 0.

Premendo  apparirà 1.

Premere  per spostarsi sullo 0 a fianco e premere  fino a quando apparirà 2.

Premere  per spostarsi sullo 0 a fianco e premere  fino a quando apparirà 3.

Premere il tasto Enter  per confermare la "Password" ed il cursore sparirà.

Premere  per tornare al menù "Cattani S.p.A.".

Per modificare i parametri del menù "User Parameters" ripetere la stessa procedura inserendo la password 0000456000.

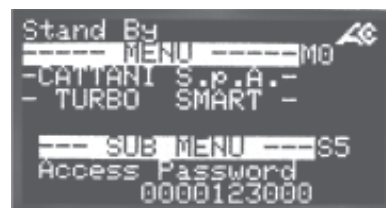
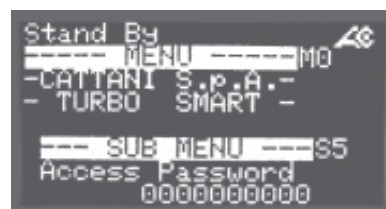
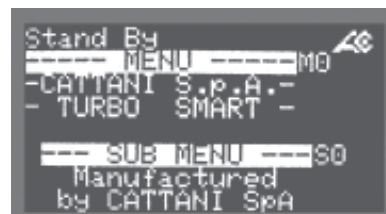
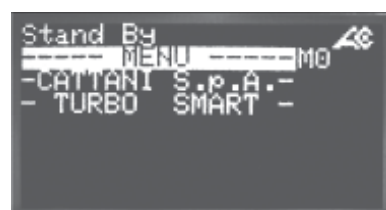
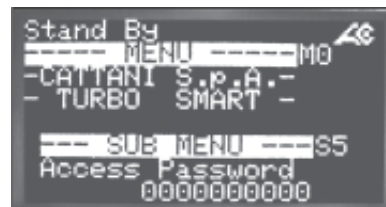

Menù "Drive Status"

Questo menù è visibile senza l'inserimento di alcuna password, ed ha la funzione di rendere visibili alcuni parametri sullo stato di funzionamento di Turbo-Smart. Qui di seguito sono indicati alcuni di questi parametri.

Frequenza soffiante
(max. 85 Hz versione A, max. 110 Hz versione B)

Tensione uscita soffiante (max. 220 V)

Corrente soffiante
(max. 5,5 A versione A, max. 7,5 A versione B)

Frequenza separatore centrifugo
(55 Hz non variabili sia per versione A che B)

Tensione uscita separatore centrifugo (max. 220V)

Corrente separatore centrifugo
(max. 5,5 A versione A, max. 7 A versione B)

scroll down button

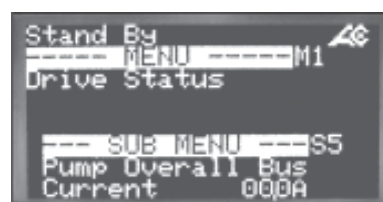
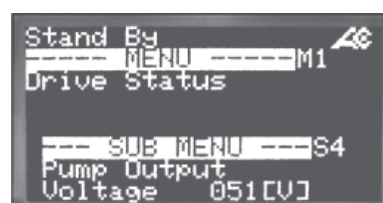
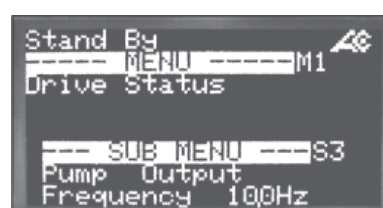
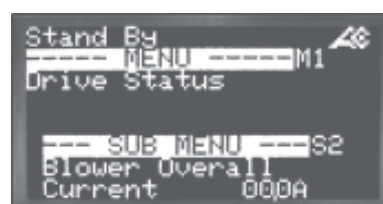
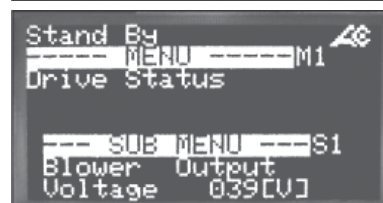
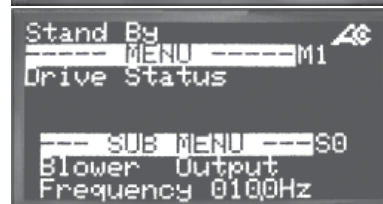

Temperatura del sistema

Massima temperatura registrata (+58 °C allarme e blocco aspiratore)



Livello di vuoto istantaneo (max. 200 mbar)

Menù "User Parameters"

A questo menù, si accede inserendo la "password di accesso" 0000123000 (vedi istruzioni a pag. 12).

Vacuum set point - Livello di vuoto-

Mostra il livello massimo di vuoto impostato.

Premere  Enter per modificare, con le frecce  impostare il valore desiderato.

Premere  Enter per confermare la modifica.

Language - Lingua -

È possibile selezionare Inglese (1), Italiano (0).

Premere  Enter per attivare il cursore e con le frecce  selezionare 0 o 1.

Premere  Enter per confermare la modifica e continuare.

scroll down button

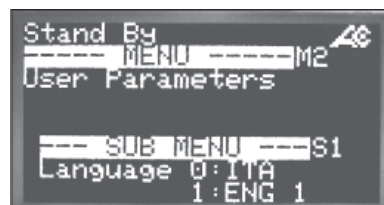
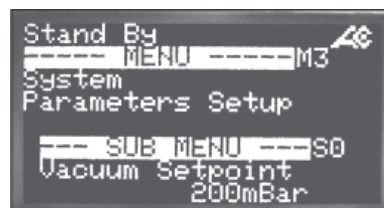
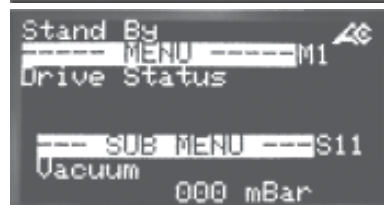
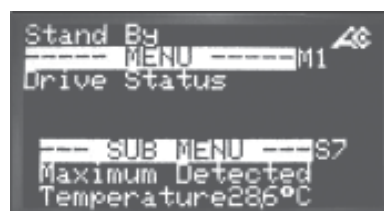
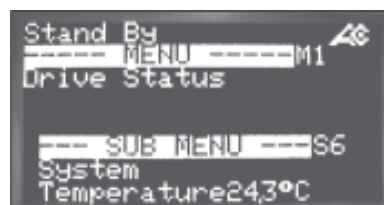

Generated code - Codice generato -

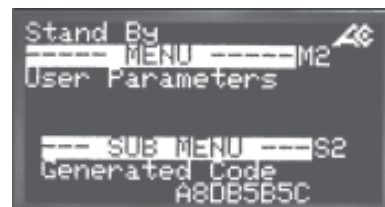

Questo codice è generato dalla Cattani S.p.A.. Ogni apparecchiatura ha un codice unico. Questo codice dovrà essere indicato alla Cattani S.p.A. per acquistare il “Codice di attivazione” per trasformare Turbo-Smart da versione A (2 riuniti) alla versione B (4 riuniti).





Activation code - Codice di attivazione -

E' il codice acquistato dalla Cattani S.p.A. per trasformare Turbo-Smart da A (2 riuniti) a B (4 riuniti).

Premere Enter  per attivare il cursore.

Usando le frecce   muoversi per inserire il Codice di attivazione e con le frecce   incrementare o diminuire il valore.

Infine, premere Enter  per confermare, quindi premere  per tornare al menù User Parameters.

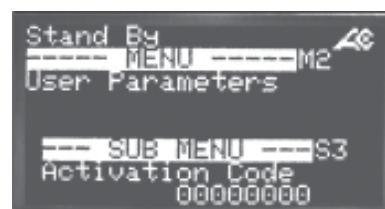



Menù “System Parameters Setup”

A questo menù, si accede inserendo la “Password di accesso” 0000456000 (vedi istruzioni a pag. 12).



Sarà ora possibile modificare alcune impostazioni.



Livello di vuoto minimo (max. 200 mbar)

Per cambiare i parametri in questo menù: Scorrere le icone dei menù con le frecce   per cercare i parametri da modificare.

Premere  Enter per attivare il cursore, con le frecce

  impostare il valore desiderato.

Premere  Enter per confermare la modifica e continuare.

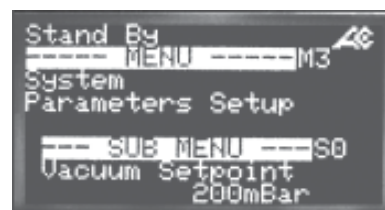

scroll down button 

Massima corrente soffiante
(max. 5,5 A versione A)
(max. 7,5 A versione B)

Ritardo spegnimento Turbo-Smart
(max. 300", min. 10")

Ritardo spegnimento separatore centrifugo
(max. 30", min. 5")

Ritardo spegnimento ventola centralino
(Default 300", Max. 1800")

Opzioni Utilizzate
Abilita o disabilita la lettura del sensore di amalgama.
0- senza separatore di amalgama
1- con separatore di amalgama

Comandi ad Inverter
Riservato a regolazioni in fabbrica.



```
Stand By
----- MENU -----M3
System
Parameters Setup
----- SUB MENU -----S1
Blower Current
Limit 055A
```

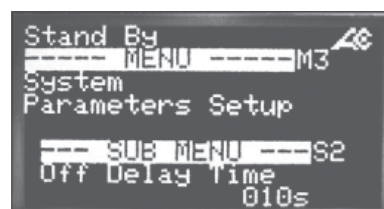

```
Stand By
----- MENU -----M3
System
Parameters Setup
----- SUB MENU -----S2
Off Delay Time
010s
```

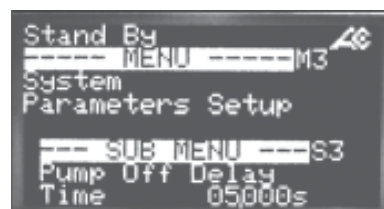

```
Stand By
----- MENU -----M3
System
Parameters Setup
----- SUB MENU -----S3
Pump Off Delay
Time 05000s
```



```
Stand By
----- MENU -----M3
System
Parameters Setup
----- SUB MENU -----S4
Fan Off Delay
Time 0300s
```



```
Stand By
----- MENU -----M3
System
Parameters Setup
----- SUB MENU -----S5
Running Options
00001
```

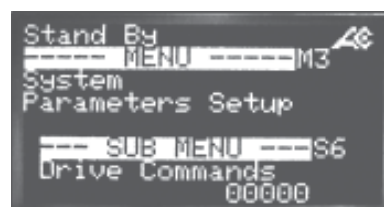

```
Stand By
----- MENU -----M3
System
Parameters Setup
----- SUB MENU -----S6
Drive Commands
00000
```

scroll down button

• Istruzioni per settare la comunicazione Zig-bee (wireless)

Settare l'indirizzo di rete della macchina
(min 100)
(max 110).

Inserire la chiave di comunicazione Zig-bee (ETRX2 USB)nella porta usb del computer e lanciare il programma di visualizzazione.

Installare il programma SMART SYSTEM MONITOR
(fornito dalla ditta Cattani S.p.A.) sul computer

```
Stand By
--- MENU --- M3
System
Parameters Setup
--- SUB MENU --- S15
Network
Address      100
```



una volta lanciato il programma comparirà per 10 secondi l'immagine aziendale dopodichè entrerà nel menù principale



cliccare sul menù SERVICE così da poter entrare nella pagina della ricerca dei dispositivi



clikkare sulla ricerca dei dispositivi disponibili, il programma inizierà la ricerca e l'operazione potrà richiedere alcuni secondi, al termine si potranno visualizzare le varie macchine disponibili ed il loro relativo codice generato, potrebbe essere necessario ripetere l'operazione più volte.

Dopo che il programma avrà trovato i dispositivi disponibili si dovrà ritornare ad home page per poter visualizzare i parametri

tramite il menù a tendina si deve scegliere quale Turbo-Smart si vuole visualizzare

a questo punto sarà possibile visualizzare i parametri funzionali.

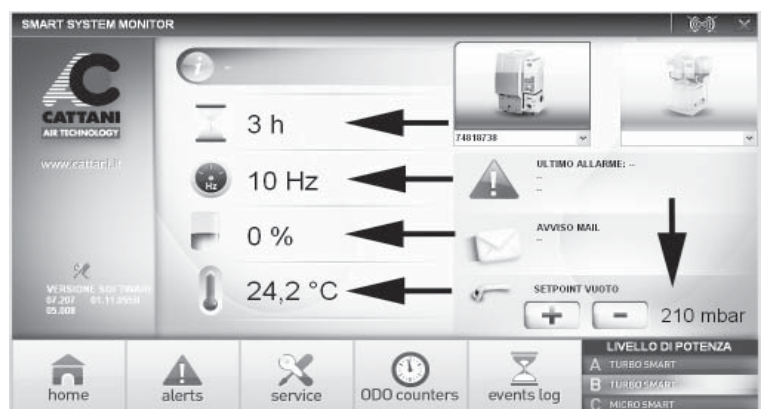
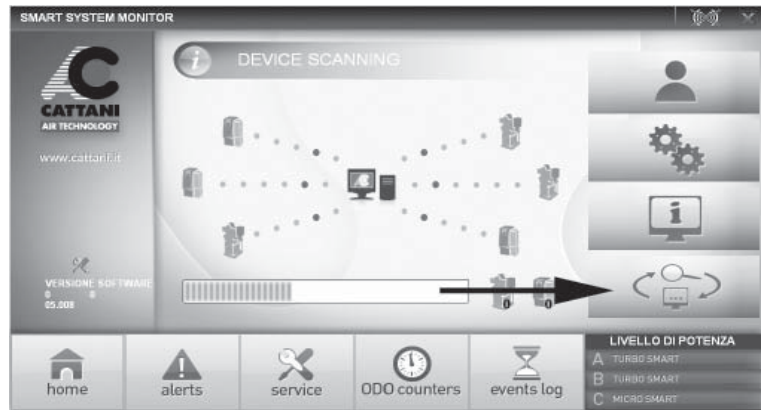

cliccando sull'icona SERVICE si potrà accedere a tre diversi menù, uno libero e 2 protetti da password

per entrare nel menù PARAMETRI UTENTE si deve digitare la password 123000 e premere ok

in questo menù è possibile cambiare la lingua, impostare il livello di pressione desiderato e trasformare la macchina da aspiratore per 2 poltrone a aspiratore per 4 poltrone grazie ad un codice di attivazione

per entrare nel menù IMPOSTAZIONI DATI DI SISTEMA si deve digitare la password 456000 e premere ok



in questo menù tecnico sono visibili e modificabili tutti i parametri del Turbo-Smart

il menù STATO INVERTER non necessita di nessuna password d'accesso e permette di visualizzare i parametri funzionali della macchina mentre sta funzionando.

dal menù principale cliccando sull'icona di posta elettronica si potranno inserire i dati, quali: indirizzo del medico e del tecnico che dovrà ricevere le comunicazioni d'allarme.

In caso di anomalia viene visualizzato un allarme nel display e viene inoltre inviata una e-mail al tecnico di riferimento.

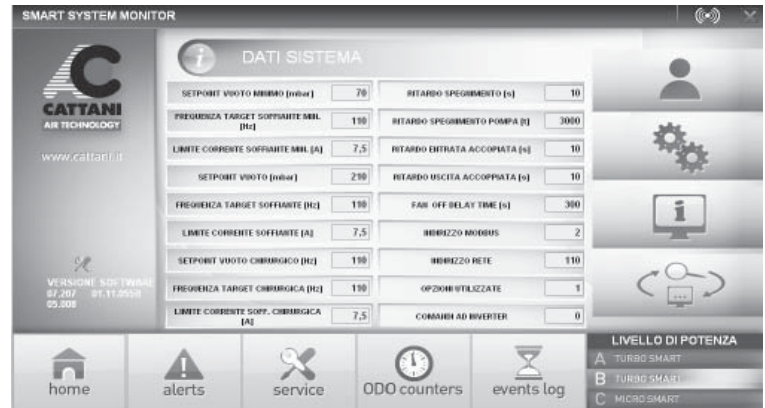

Gli eventuali allarmi avvenuti durante la giornata, sono visualizzati con un codice di errore e la sua descrizione è visibile all'interno della casella ALERTS.

Nella cartella EVENT LOG si potrà visualizzare tutto lo storico degli allarmi accorsi alla macchina durante tutto il periodo di funzionamento

nel menù ODO COUNTERS vengono memorizzati i cicli di attivazione del Turbo-Smart.

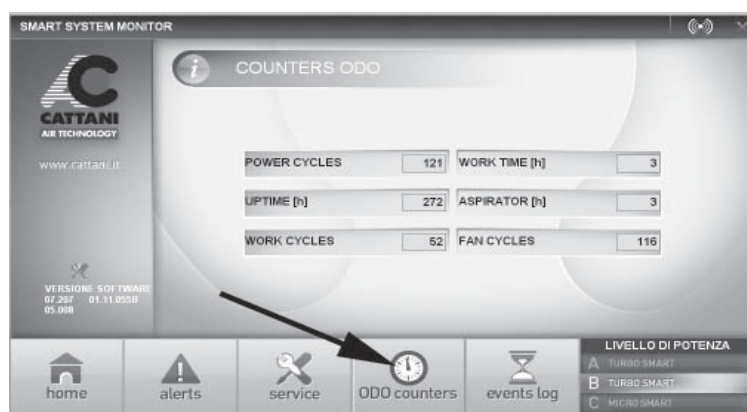
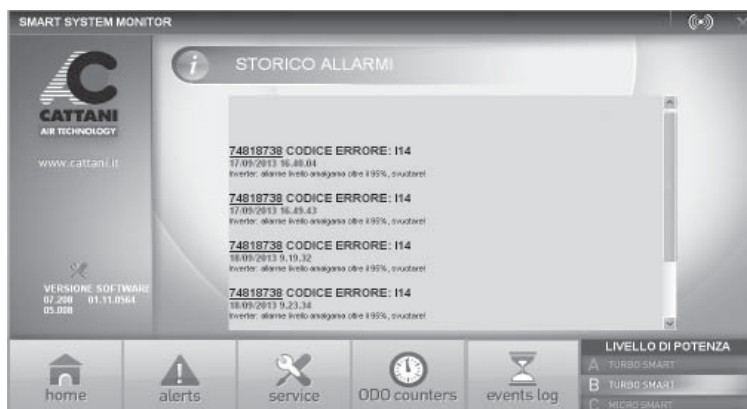

• *Descrizione allarmi*

Codice allarme AC80 AC80-07		DESCRIZIONE	SOLUZIONE
00	0	Allarme memoria microcontrollore	Contattare il tecnico
I14	2	Superato il 95% livello amalgama	Sostituire il contenitore amalgama appena possibile
I15	3	Superato il 100% livello amalgama	Sostituire il contenitore amalgama
I00	32	Allarme memoria microcontrollore	Contattare il tecnico
I01	33	Cortocircuito dovuto ad uno dei due motori	Verificare da dove proviene il cortocircuito ed eliminarlo
I02	34	Cortocircuito prima del comando motori	Contattare il tecnico (probabile scheda danneggiata)
I03	35	Mancata carica condensatori	Contattare il tecnico (sostituire la scheda)
I04	36	Superata soglia di temperatura	Aerare il locale macchine
I05	37	Superata soglia di corrente soffiante	Verificare il funzionamento della soffiante (blocco o resistenza eccessiva)
I07	39	Superata massima tensione sui condensatori	Verificare la tensione di rete max. 260V
S08	40	Cortocircuito centrifuga	Rimuovere il cortocircuito
S09	41	Cortocircuito della scheda nell'uscita centrifuga	Sostituire la scheda
S10	42	Superata soglia di corrente centrifuga istantanea	Eliminare i sifoni nella tubazione o verificare il funzionamento della centrifuga (blocco o resistenza eccessiva)
S11	43	Superata soglia di corrente centrifuga ritardata	Eliminare i sifoni nella tubazione o verificare il funzionamento della centrifuga (blocco o resistenza eccessiva)
I13	-	Lettore amalgama scollegato	Collegare il sensore amalgama
I16	48	Tubo sensore di vuoto scollegato	Collegare il tubo del vuoto con la centrifuga
I17	49	Apertura pastiglia termica centrifuga	Aerare l'ambiente

- *Avvisi importanti*
- *Trasporto e stoccaggio*
- *Trasporto di apparecchi usati*

• *Avvisi importanti*

- Gli apparecchi sono in garanzia per un anno dalla data di vendita, a condizione che si ritorni alla casa costruttrice il talloncino di garanzia con indicato: data di vendita, venditore e cliente utilizzatore.
- Con l'acquisto di una speciale dotazione di prodotti per la pulizia e disinfezione si può ottenere una estensione di garanzia di ulteriori 12 mesi, vedi listino.
- La garanzia e la responsabilità del fabbricante decadono quando gli apparecchi vengono trattati con prodotti non idonei o diversi da quelli indicati dal costruttore, utilizzati in modo scorretto, e quando vengono manomessi con interventi di qualsiasi natura da persone non autorizzate dal fabbricante.
- La casa costruttrice, i concessionari, gli agenti ed i tecnici autorizzati, sono a disposizione per consigli, indicazioni, e per fornire documentazione, pezzi di ricambio, e quant'altro possa essere utile.
- Esigenze tecniche, miglioramento dei prodotti, problemi normativi e funzionali, difficoltà di reperibilità dei prodotti o dei semilavorati, possono indurre la casa costruttrice ad apportare modifi che alla produzione senza preavviso.
- Nel sito internet **www.cattani.it** sono rintracciabili i nostri manuali **aggiornati**. Ne consigliamo la consultazione specialmente per gli aggiornamenti sulla **sicurezza**.
- Turbo-Smart è una apparecchiatura AEE, perciò soggetta alla normativa RAEE (Rifiuti di Apparecchiature Elettriche ed Elettroniche).

• *Trasporto e stoccaggio*

- Nel trasporto e nello stoccaggio le attrezzature imballate potranno essere sottoposte alle temperature di -10 °C e + 60 °C.
- I colli non potranno essere esposti all'acqua ed agli spruzzi e non potranno sopportare umidità superiore al 70%.
- I colli sono sovrapponibili solo in terza fila con il medesimo peso.

• *Trasporto di apparecchi usati*

- Prima di imballare, si consiglia di detergere e disinfettare l'aspiratore con Fast & Steril 3 (vedi i capitoli "Segnali ed avvisi" e "Manutenzione ordinaria").
- Vuotare tutti i tubi e le comunicazioni esterno/interno, eventuali residui di liquido (anche disinfettante) potrebbero danneggiare il centralino. Togliere il vaso di raccolta amalgama, aggiungere il disinfettante, chiudere il vaso con il coperchio a tenuta. Ad aspiratore asciugato esternamente ed internamente, chiudere tutte le comunicazioni esterno/interno con gli appositi tappi, montare un vasetto raccolta amalgama nuovo, avvolgere separatamente apparecchio e il centralino, in modo da impermeabilizzarli al massimo.
- Chiudere l'apparecchio in un sacco di polietilene ed imballare in cartone a tre onde.



TURBO SMART

A UNIVERSAL ASPIRATOR

INDEX

General 50/60 Hz running data.....	26
Introduction	27
Signals and warnings	27
Installation and starting	28
Routine maintenance	32
Extraordinary maintenance	33
Instructions to navigate Turbo-Smart menus and to modify some parameters	34
Instructions for communication settings Zigbee (wireless)	41
Alarms description	46
Important notices	47
Transport and storage	47
Transport of second-hand appliances	47
Pictures	121

- *General 50/60 Hz running data
Turbo-Smart dental aspirator*

Model	Turbo-Smart "A"	Turbo-Smart "B"
Rated voltage	230 V ~	230 V ~
Rated frequency	50/60 Hz	50/60 Hz
Rated current	7 A	9 A
Operating conditions	Continuous operation	Continuous operation
Protection against ingress of liquids	Ordinary	Ordinary
Max. absorbed power	1,45 kW	1,87 kW
Max. flow	86 m ³ /h	105 m ³ /h
Max. head for continuous service	2000 mm H ₂ O	2000 mm H ₂ O
Rotation speed	70 Hz 85 Hz	70 Hz 110 Hz
Sound pressure version without box	68.4 dB(A) 69 dB(A)	68.4 dB(A) 73.7 dB(A)
Sound pressure version with plastic box	66.4 dB(A) 67 dB(A)	66.4 dB(A) 72 dB(A)
Sound pressure level version with box for indoor installation	48.5dB(A)49.5dB(A)	48.5 dB(A) 52.2 dB(A)
Sound pressure level version with box for outdoor installation	54 dB(A) 55 dB(A)	54 dB(A) 58.7 dB(A)

~	Alternating current	IEC 417-5032
⊕	Earthing	IEC 417-5019
	Degree of protection against electric shock	IEC 60204-1
○	Open (disconnected from the main electrical supply)	IEC 417-5008
I	Closed (connected to the main electrical supply)	IEC 417-5007

Sound pressure level tested according to the standard ISO 3746-1979 (E).
Parameters: r = 1,5 – background noise: 34 dB (A) – instrument Bruel & Kjaer type 2232

- *Introduction*
- *Signals and warnings*

- **Introduction**

This booklet is intended to illustrate the installation and starting of the appliance.

It also informs of possible dangers and about the precautions to be taken for accident prevention.

This manual should be always available for consultation during unpacking, use, installation and starting of Turbo-Smart.

Our **updated** manuals are available on the web site **www.cattani.it**. We recommend their consultation especially for updates about **safety**.

- **Signals and warnings**

- *Electrical shock risk: also 230 V \sim can be lethal.*



- *Biological danger, risk of infections from epidemic diseases.*



- *General danger sign.*



- *Personal protections for heavy works.*



- *Personal protections against biological danger.*



- *High temperature.*



- *Keep the room free from flammable, corrosive or explosive material.*



- *Compulsory direction of flow or of rotation.*



Warning signs cannot always fully express danger warnings, therefore it is necessary that the user reads the warnings and keeps them in due consideration.

Failure to observe a danger sign or warning may harm operators or patients.

Safety devices must not be removed. Appliances or their functioning must never be modified.

Despite all our efforts, it is still possible that danger warnings are not exhaustive: we apologise to the users and kindly request them to care for all danger sources that might have passed unnoticed and to inform us accordingly.

• Installation and starting

• Recommended precautions

Before unpacking the appliance, check the warning shock-watch on the carton. In case of it being red or the carton being damaged, accept the material reserving the right to examine the machine.

Unpack the appliance following the instructions shown on the package. The carton is recyclable. Dispose of it in compliance with regulations in force. Retain the plastic caps that cover all inlets and outlets of the unit, as they must be used if the machine needs to be moved or transported.

The machine installation must be carried out by a specialist equipped with the necessary tools. Install the appliance in a clean location, far from heat sources, humidity and dust. Turbo-Smart can be installed outdoors (on a balcony, in veranda or gardens), provided that it is sheltered from rain, splashing, humidity, frost and direct sunshine.

For outdoor installation we recommend the use of our special designed box fitted with double isolating roof, anti-freeze and ventilation systems (both fitted with fixed thermostat for automatic temperature control).

In the plant room temperature can range from a minimum of + 5 °C to +35 °C max.

Turbo-Smart fitted with box, for indoors our outdoors installation, can be supplied with antifreeze device. In case the plant room must be ventilated or air-conditioned, we suggest to contact a thermo-technician for a personalized project. The plant room must be closed to patients and extraneous people. If such a room is not available, machines must be protected by a suitable cover, which must not be easy to remove. Use protections and danger warning boards to prevent accidental risk from electrical shocks or the possibility (unlikely but not excludible) of fire, explosion and contaminating air or liquid leakage. Use indoors and outdoors boxes designed and produced by the manufacturer of the machines only.

Keep the plant room free from flammable material. Make sure that there is no possibility for gas leakages. Do not connect damaged appliances to the mains. Do not use extension leads, multiple plugs or sockets. Before connecting the machine to the mains, ascertain that the feeding line is complying with the regulations C.E.I. 64-8 and that a thermal switch and a residual current operated circuit-breaker (class A or B) **(16A)** according to the regulations EN 61008-1 are present. Light coloured, wooden, linoleum, rubber or marble floors can change colour or get marked if they are kept in contact with rubber vibration-proof devices **(1)**. Therefore, it is necessary to use a rubber sheet or some other suitable material to isolate vibration-proof devices from the floor.

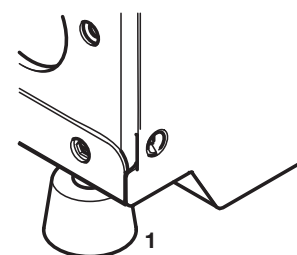
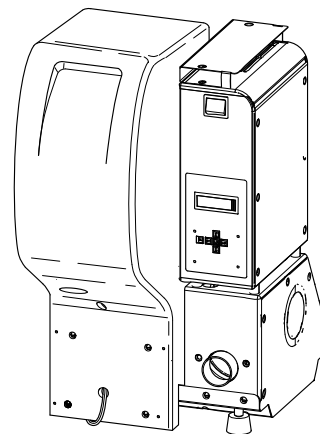
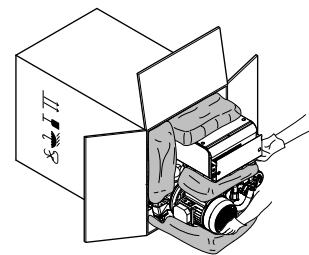

• Installation

Before connecting the aspirator to the piping of the centralized system, ascertain that aspiration piping is clean as heavy debris could damage the appliances.

Connect the PVC light grey aspiration tube **(2b)** (supplied with the machine) to the 50 mm Ø tube-holder **(2)** ("aspirated fluid inlet").

The other end of the same tube must be connected to the aspiration piping **(3)** coming from the surgeries (page 30).

The black heat resistant exhaust air pipe **(4b)**, fitted with a metal spiral, must be connected to the 50 mm Ø tube-holder **(4)** ("exhaust air outlet").

Connect the other end of the pipe to the antibacterial filter **(5)**, passing preferably through a silencer **(5a)** supplied with the aspirator. The hot air coming from the antibacterial filter must be conveyed outside.

Connect the 18 mm Ø tube-holder **(6)** to the liquid drain pipe. In the version fitted with Hydrocyclone the aspirator is draining liquids by gravity, therefore these can never be drained towards the top. The 10 mm Ø tube-holder **(8)** ("emergency drain") must be connected to the liquid drain pipe.

The piping connecting the machine to the aspiration and draining system should be flexible to dampen the small vibrations produced by the aspirator.

The aspiration piping should be run in the floor and at a point near the aspirator it should rise about 30 cm to reach the tube-holder **(2)** (fig. A and B, page 121).

If Turbo-Smart is installed on a lower floor than the dental units, the aspiration piping must not enter the centrifugal separator perpendicularly.

Rather, place a few metres of piping horizontally on the same level of the machine and then install it at the centrifugal separator inlet which is on a higher level (use a flexible pipe) (fig.B, page 121). The aspirated fluid is reaspirated by Turbo-Smart.

After the installation, connect the power cable to the mains according to the regulation EN 61008-1.

Finally connect the low voltage users line: the clamps 19 and 20 of the circuit AC80-07 (fig. C "AC80-07 wiring diagram", page 122) to the users line **(12)** (det.12, page 30 and fig. F, page 125) which is feeding all the dental units of the same system with connections in parallel.

Ascertain that the contact on the dental unit is clean (free contact without voltage).

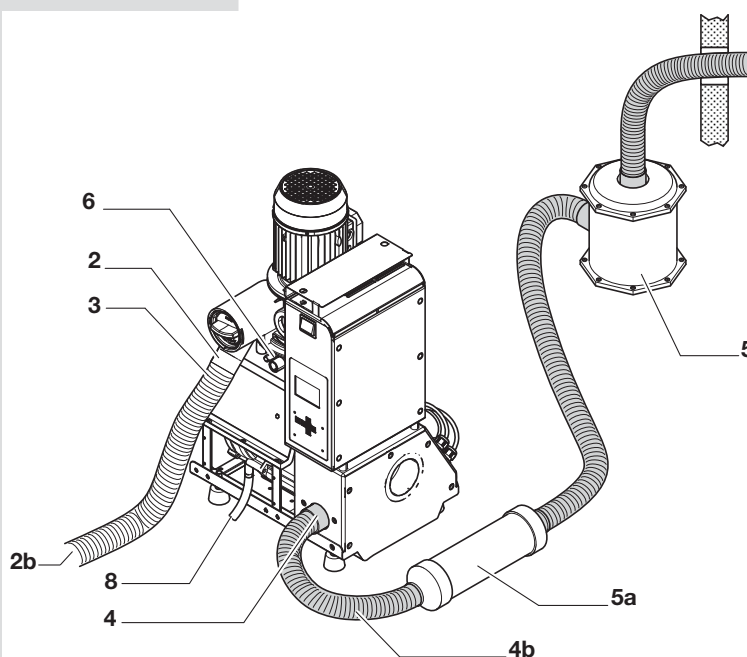
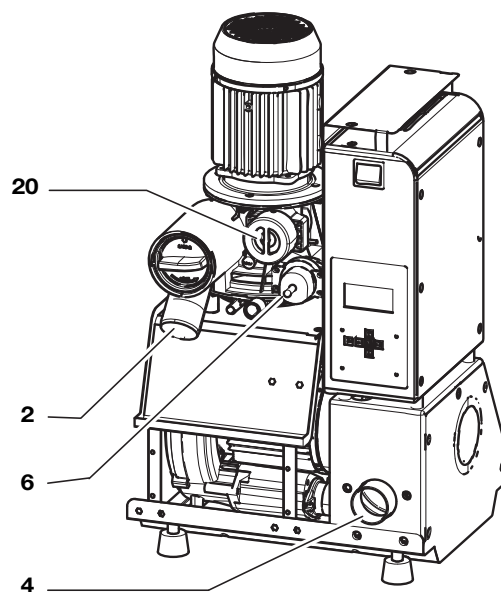

- **Installation in parallel**

It is advisable to install in parallel only machines with the same flow and head values. With the installation of 2 or 3 Turbo-Smart units in parallel (fig. F) the total flow is doubled or tripled, provided that the diameter of the main piping is increased of 10 mm for each additional aspirator unit. In the same way the diameter of the exhaust air pipe must be increased. Turbo-Smart is supplied complete with all the accessories which are necessary for the installation in parallel, therefore no one-way valves, supplementary control panels or peripheral units are needed. After connecting 2 or 3 Turbo-Smart units in parallel to the same main piping, connect in parallel the users wires **(12)** coming from the different dental units. Installing Turbo-Smart units in parallel, pay attention not to invert the small cables of the connection no.19 with the small cables of the connection no.20. With multiple aspirators in parallel it can occur that one unit stops and that the operators do not notice it. In order to bring this to the clinic staff's attention, the connections 8 and 9 of the control panel (clean contact) allow a remote alarm signal to be connected in a room under frequent control. More Turbo-Smart units in parallel can offer better performance and allow the clinic to save energy when they are working simultaneously, independent of the suction demand. Disconnecting one or more aspirators doesn't result in a saving of energy and also decreases the suction power of the other machines.

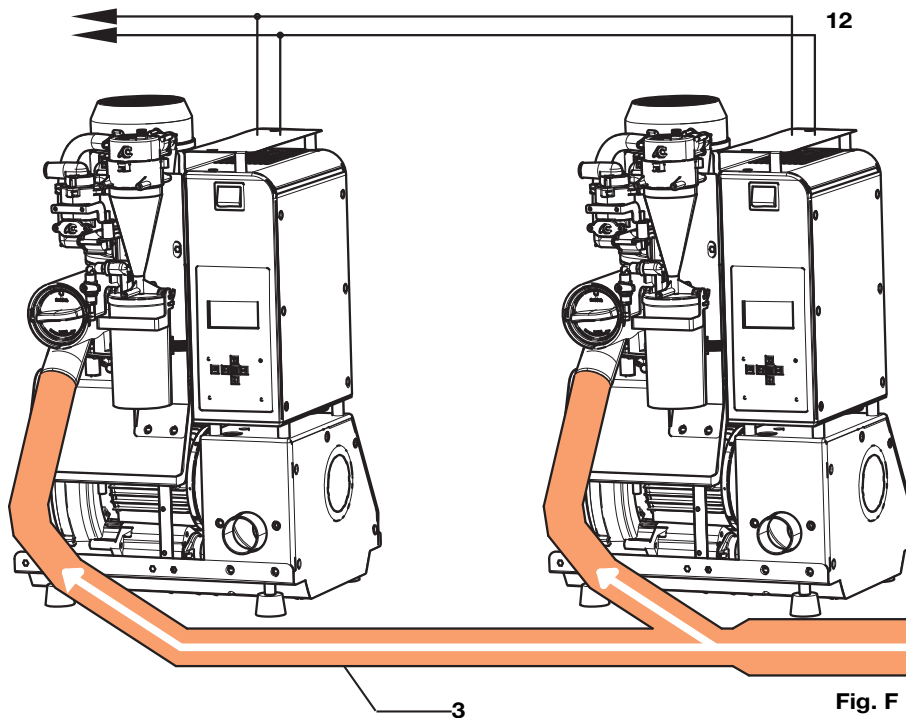
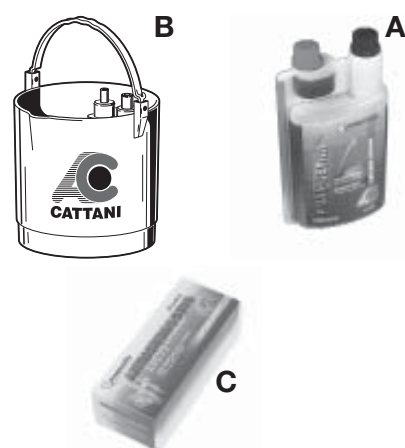

Fig. F

Draw. F

Starting, final test and users instruction

Install and connect the aspirator, select the position ON on the switch, which will light up after one of the dental units has started working. At this point aspiration will start. To check if Turbo-Smart is working correctly, it is advisable to carry out the dynamic tests (see fig. D, page 123 and the Turbo-Smart working diagram fig. E, page 124). Users must be instructed on the aspirator use and routine maintenance of new, not used, and therefore not yet contaminated, machines. Show users how to follow the Turbo-Smart working phases on the display, to interpret danger warnings and to carry out routine maintenance using Puli-Jet plus new with anti-scaling agent **(A)** - (by means of Pulse-Cleaner) **(B)** - and disinfectant Antifoam Tablets **(C)**.



Working

The aspirating unit **(9)** (through pipe **10**) creates vacuum inside the centrifugal separator **(11)**. The fluid coming from the dental units enters the centrifugal separator **(11)** from the collecting pipe **(2)**. The centrifugal separator separates air from liquids: air is exhausted outside through the pipe **(4)** whereas liquids (in the version without amalgam separator) are drained to the sewage through the waste pipe connected to the tube-holder **(6)**. The centrifugal separator **(11)** is starting before the aspirating unit **(9)**, this allows to drain the liquids which might collect inside the centrifugal separator before aspiration starts. Moreover, when the machine is switched off a timer (adjustable) is keeping the motor running for min. 10" - max. 120".

Amalgam Separator ISO 18

On request, Turbo-Smart can be supplied with the amalgam separator "Hydrocyclone ISO 18" having its separate manual.

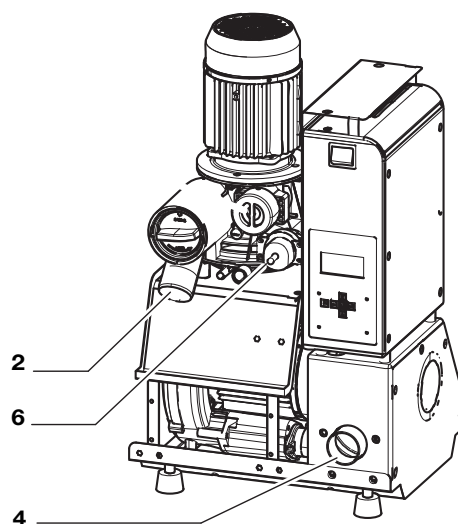
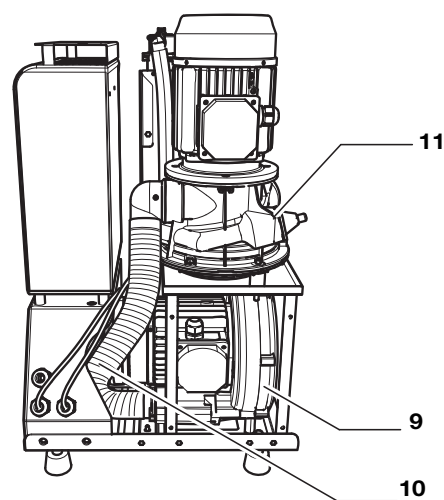

• Routine maintenance

Routine maintenance must be entrusted to specially instructed surgery staff.

- We recommend to pay special attention to all danger signals and to use goggles, gloves and disposable overalls for personal protection.

Daily

- Check for any possible alarm on the display. In case of alarms, contact the technician.

Every evening

- At the end of every working day aspirate a solution of Pu-li-Jet plus new disinfectant with anti-scale agent **(A)** using Pulse Cleaner **(B)**;
- Disconnect the machine from the mains before any intervention.

Daily

- Place the Antifoam Tablets on the dental unit filters.

Periodically

- Keep the aspirator filter clean.

Occasionally

- Make sure that the aspirator ventilation is not obstructed;
- Keep the plant room free from anything not related to the machines, especially from flammable material. Make sure that there is no possibility for the formation of corrosive, flammable and explosive mixtures.



ALLARME:
TEMPERATURA ELEVATA

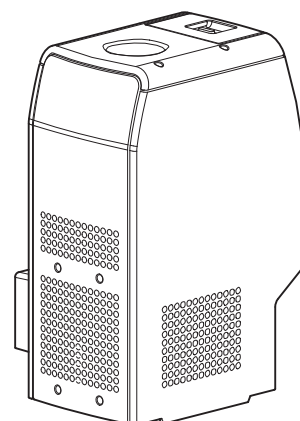
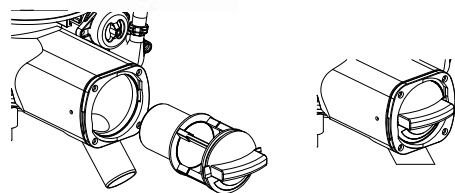
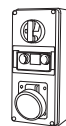
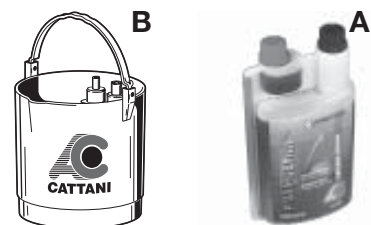

• *Extraordinary maintenance*

Extraordinary maintenance must be entrusted to a trained technician in possession of original spare parts:

- pay special attention to danger signals. Use goggles, gloves and disposable overalls for personal protection;
- check that routine maintenance has been duly carried out and make sure that Magnolia products are used;
- before any intervention carry out a series of washes with Fast & Steril 3 (D), then wait 15 minutes for a complete disinfectant action.

Every 12 months

- Check maximum detected temperatures and all alarms. Intervene accordingly;
- check the aspirator noise level (max. 72 dB according to the regulation 3047 (E));
- if necessary, remove dust from the circuit AC80 inside electronic components using a blast of dry air not exceeding 2 bar pressure. By means of a 6 bar blast of air clean also the small holes on the frontal cover of the aspirating unit (15);
- check the conditions of plastic hoses, in particular the hoses under pressure connecting the centrifugal separator and the Hydrocyclone ISO. We suggest to replace these hoses every 12-18 months.

Every 18-24 months

- Check the working conditions of the centrifugal separator (11) and re-circulation valve (14).

Every 10.000 working hours

- Every time a component containing a rubber part ("O" ring, gasket or seal) is disassembled, replace the rubber part;
- replace the motors bearings;
- where routine maintenance is not carried out properly or unsuitable products are used, train the staff and inform the person in charge.

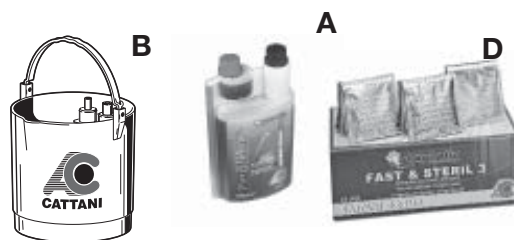

ALLARME:
TEMPERATURA ELEVATA

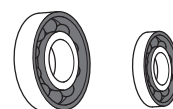
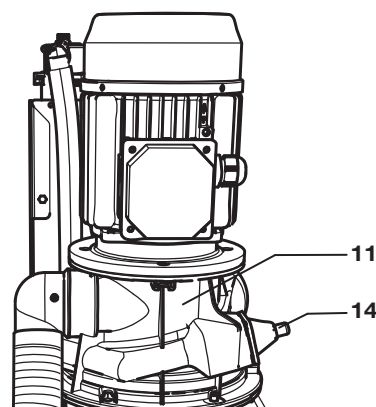
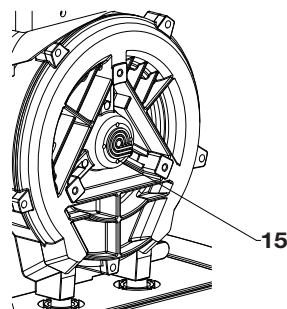

- *Instructions to navigate Turbo-Smart menus and to modify some parameters*

Main menus

When Turbo-Smart is switched on, the display shows the Cattani logo for 10 seconds, after which time the main menu appears.



Main Menu "A1"

This menu shows some parameters such as: cycles, suction activation time, temperature, presence/absence of the amalgam container and system software release.



Control Menu "A2"

The display shows the number of times Turbo-Smart has been switched on by means of the main switch (Power Cycles), the total hours Turbo-Smart has had power supplied (Uptime), the number of times suction has been activated (Work Cycles), the total running hours of the aspirator (Work Time), the average working hours of the blower (Aspirator) and the number of times the control panel cooling fan has been activated (Fan Cycles).

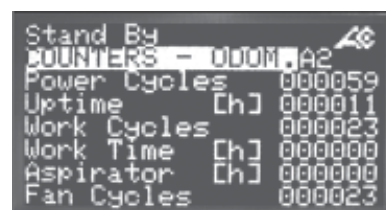

Events Menu "A3"

The menu shows the last 10 events or alarms that have occurred to Turbo-Smart. Alarms are indicated with a number; refer to the table at page 46 to identify them.



Control Menu "A2"

COUNTERS - ODOM . A2		
POWER CYCLES	000000	Number of times the aspirator has been switched on by means of the main switch.
UPTIME [h]	000000	Total hours Turbo-Smart has had power supplied.
WORK CYCLES	000000	Number of times the aspirator has been activated by the dental unit.
WORK TIME [h]	000000	Number of real running hours (motors running).
ASPIRATOR [h]	000000	Average working hours of the aspiration motor (UNI-JET 75).
FAN CYCLES	000000	Number of times the control panel cooling fan has been activated.

Secondary Menu

Press  to enter the Secondary Menu.

Pressing the  key takes you through the other menus.

Drive Status

This menu can be accessed without any access password. The display shows useful information about the Turbo-Smart functioning.

User Parameters

Use the password 0000123000 to enter this menu.

From this menu the Vacuum Set Point and the unit's displayed Language can be set, as well the Activation Code can be entered to upgrade version A to version B.

System Parameters Setup

The password 0000456000 must be entered to gain access to this menu. From this menu Off Delay Time and other technical parameters can be set.

Factory Settings Restricted Access

This menu cannot be accessed by the user. It can be entered by the manufacturer only.

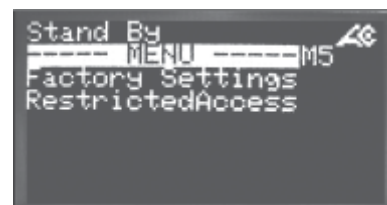
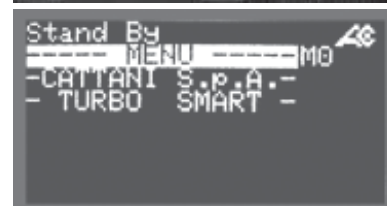



scroll down button
↓

Entering Access Passwords

The Drive Status menu is the only menu that can be accessed without the use of an access password.



To enter the User Parameters menu the access password is 0000123000.





To enter the System Parameters Setup menu the access password is 0000456000.

From the CATTANI S.p.A. menu, press  and then .

The Access Password screen Access Password 0000000000 should then be displayed.

Press the  Enter Key which will make a cursor appear on the last zero to the right.

Press  until the cursor is flashing on the 6th zero. Press  until number 1 appears.

Press  to move to the next zero and then press  until number 2 appears. Press  to move to the next zero and then press  until number 3 appears.

Press the  Enter Key to confirm the password. The cursor will disappear.

Press  to return to the Cattani S.p.A. menu.

It is now possible to modify the parameters of the User Parameters menu.

Repeat the same process and enter the password 0000456000 to gain access to the System Parameters Setup menu.

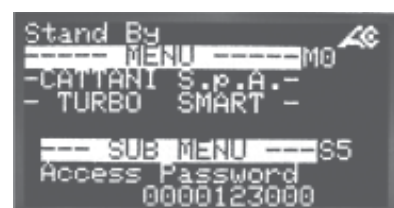
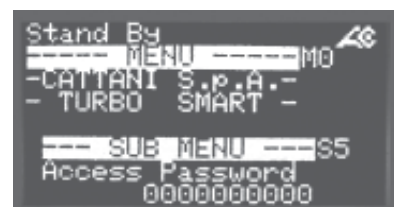
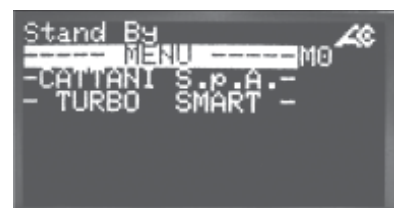
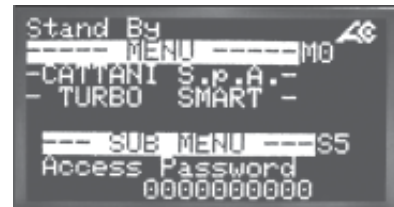

Drive Status menu

This menu can be accessed without any access password. It displays various technical parameters regarding the real-time working conditions of Turbo-Smart. Listed below is the more commonly required information.

Blower Output Frequency

(max. setting for version A: 85 Hz
max. setting for version B: 110 Hz)

Blower Output Voltage

(max. setting: 220V)

Blower Overall Current

(max. setting for version A: 5,5 A
max. setting for version B: 7,5 A)

Pump (Centrifuge) Output Frequency

(fixed setting for versions A and B: 55 Hz)

Pump (Centrifuge) Output Voltage

(max. setting: 220V)

Pump (Centrifuge) Overall Bus Current

(max. setting for version A: 5,5 A
max. setting for version B: 7 A)

scroll down button

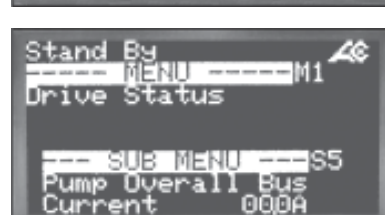
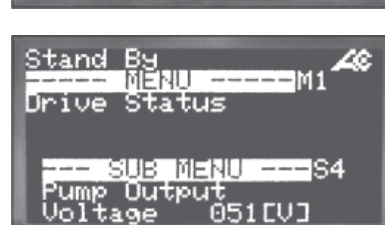
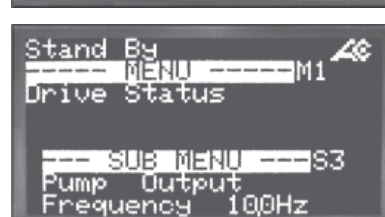
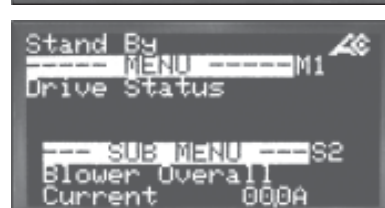
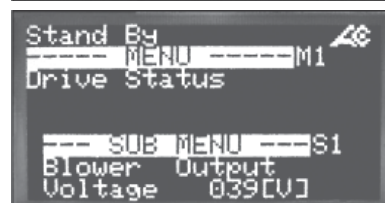
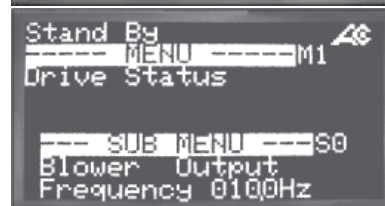

System Temperature

Maximum Detected Temperature
(+58 °C: Alarm and Stop of the aspirator)





Vacuum
(max. setting: 200 mbar)

User Parameters menu

To access this menu you are required to enter the access password 0000123000 (see instructions on page 36).



Vacuum Set Point

This is the figure to which the unit will limit the vacuum.

Press the  Enter Key to make the cursor appear. The figure can be changed using the arrow keys  . Press the  Enter Key again to confirm and continue.

Language

It is possible to choose either English (1) or Italian (0) for the displayed language.

Press the  Enter Key to enable the cursor and use the arrow keys   to select 0 or 1.

Press the  Enter Key again to confirm the change and continue.

scroll down button

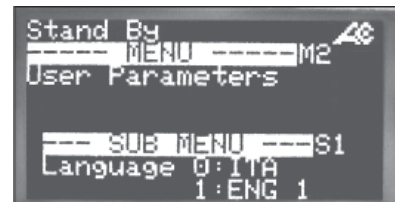
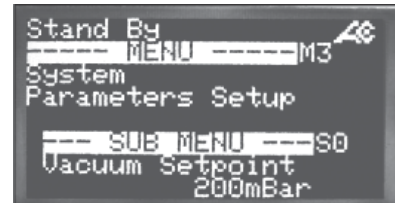
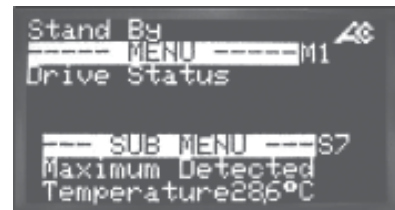
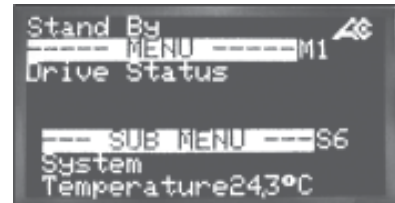





Generated Code



This code is generated by Cattani S.p.A. Each unit is allocated a unique code. This code needs to be supplied to Cattani to purchase the password (Activation Code) to upgrade version A (2 chair unit) to version B (4 chair unit).

Activation Code

Once purchased from Cattani S.p.A., this code is entered at this point to upgrade version A (2 chair unit) to version B (4 chair unit).

Press the  Enter Key to make the cursor appear.

Use the   keys to move the cursor. Enter the Activation Code using the keys   to increase or decrease the figure.

Press the  Enter Key again to confirm, then press  to go back to the User Parameters menu.



System Parameters Setup menu



To access this menu and/or make any changes, you are required to enter the access password 0000456000 (see instructions on page 36).

Vacuum set point

(Max.setting: 200 mbar)

To change any parameters in this menu:

Scroll with   through to display the required parameter.

Press the  Enter Key to enable the cursor. The figure can be changed using the arrow keys  .

Once the figure has been set to the desired figure, press the Enter Key again to confirm and continue.

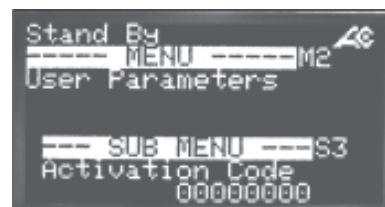
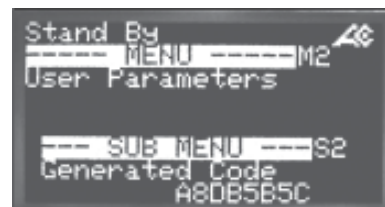

scroll down button



Blower Current Limit

(Max. setting for A: 5,5 A

Max. setting for B: 7,5 A)

Turbo-Smart Off Delay Time

(Max. setting: 300 sec.

Min. setting: 10 sec.)

Pump (Centrifuge) Off Delay Time

(Max. setting: 30 sec.

Min. setting: 5 sec.)

Control Panel Fan Off Delay Time

(Default setting: 300 sec.

Max. setting 1800 sec.)

Running Options

This enables or disables the amalgam level sensor.

Set to 0: without amalgam separator

Set to 1: with amalgam separator

Drive Commands

Factory use only.

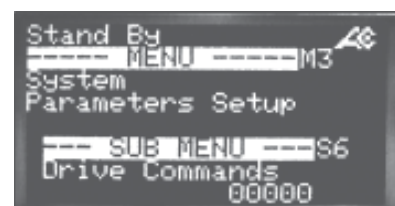
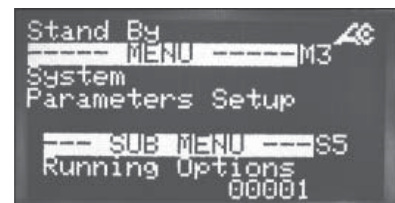
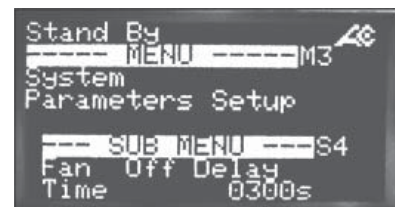
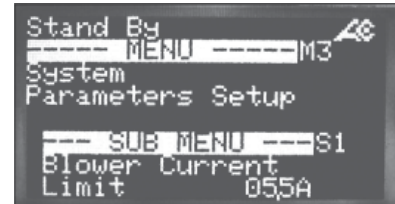

scroll down button

- *Instructions for communication settings Zigbee (wireless)*

Set the network address of the machine (min 100) (max 110).

Enter the Zig-bee communication key (ETRX2 USB) in the USB port of the computer and launch the display program.

Install the SMART SYSTEM MONITOR program (supplied by Cattani) in the computer.

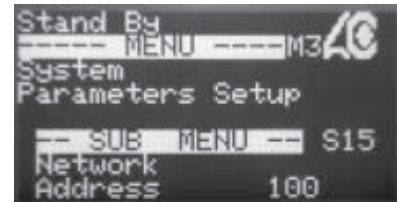

Once the program is launched, the company's logo will appear for 10 seconds followed by the main menu.



Click on the SERVICE menu so that you can access the device search page.



Click on available device search, the program will start the search and the operation may require a few seconds. When completed, you will be able to view the various machines available and their generated code; you may need to repeat this operation a number of times.

Once the program has detected the available devices, you will have to go back to home page in order to view the parameters.

Use the dropdown menu to choose which Turbo Smart you want to view.

the functional parameters will then be displayed.

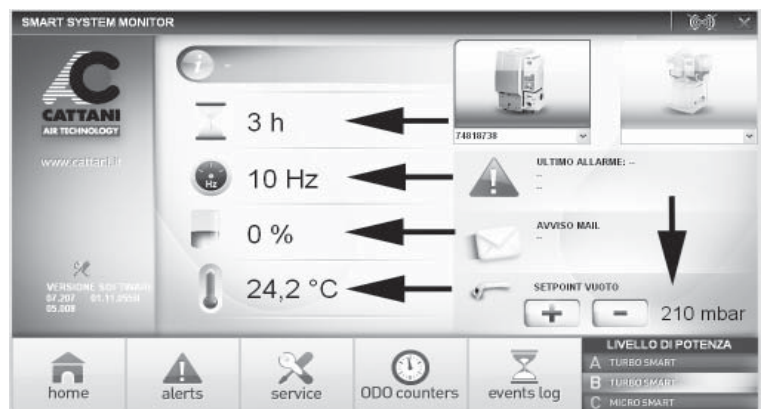
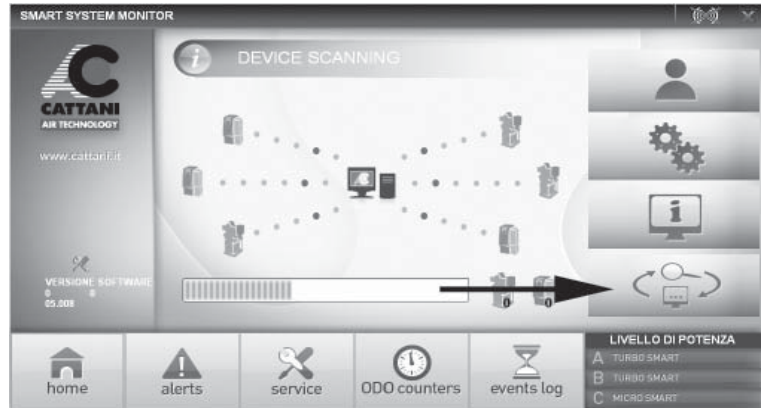

Clicking on the SERVICE icon gives access to three different menus, an open one and 2 protected by password.

To enter the USER PARAMETERS menu, enter the password 123000 and press OK.

In this menu you can change the language, set the desired level of pressure and switch the machine from aspirator for 2 dental units to aspirator for 4 dental units, thanks to an activation code.

To enter the SYSTEM DATA SETTINGS menu, enter the password 456000 and press OK.



In this technical menu you can view and modify all the parameters of the Turbo Smart.



The INVERTER STATUS menu, which does not require an access password, displays the functional parameters of the machine while it is in operation.



From the main menu, click on the email icon to enter data such as the address of the doctor or technician to which alarm communications must be sent.



In case of malfunction, an alarm will be shown on the display and an email sent to the technician in charge.

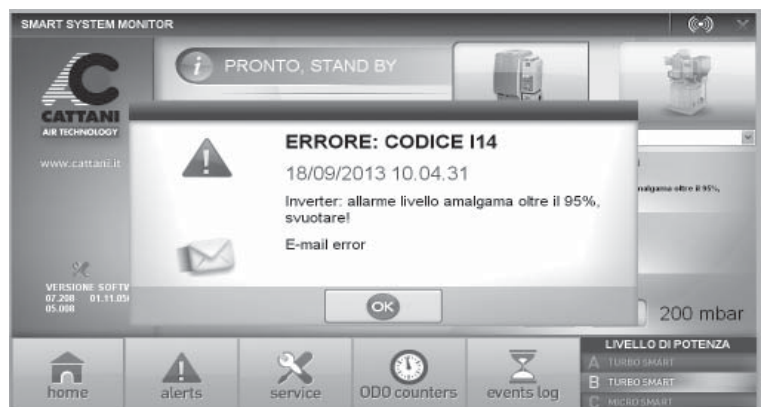

Any alarms generated during the day are displayed with an error code and a description in the ALERTS box.



The full history of all the alarms occurred in the machine during the entire period of operation can be viewed in the EVENT LOG folder.

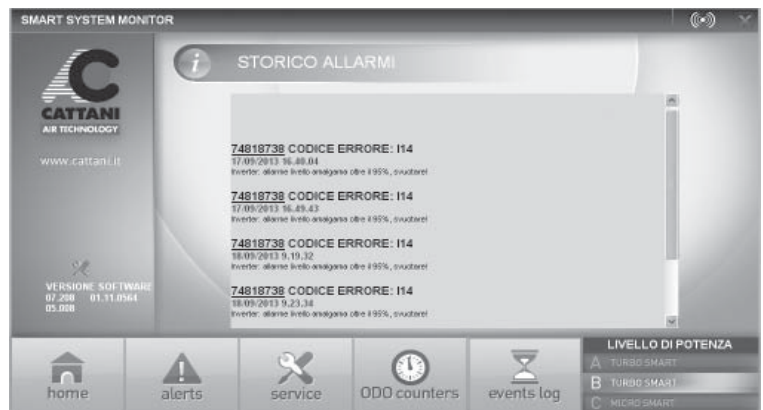

The operation cycles are saved in the ODO COUNTERS menu.

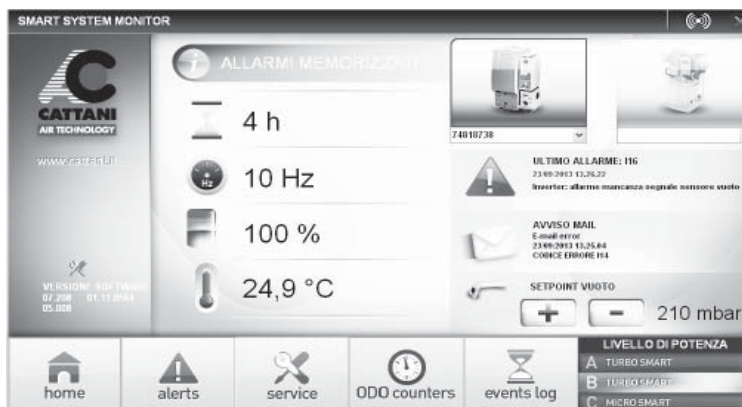

- *Alarms description*

Alarm code		DESCRIPTION	SOLUTION
AC80 AC80-07			
00	0	Microcontroller memory alarm	Contact the technician
I14	2	Amalgam level > 95%	Replace the amalgam container as soon as possible
I15	3	Amalgam level > 100%	Replace the amalgam container
I00	32	Microcontroller memory alarm	Contact the technician
I01	33	Short-circuit due to one of the two motors	Identify where the short-circuit is coming from and eliminate it
I02	34	Short-circuit before the motors' starting	Contact the technician (the PC-Board is likely to be damaged)
I03	35	Condensers have not been charged	Contact the technician (replace the PC-Board)
I04	36	Overtemperature (temperature has exceeded the max. allowed limit)	Ventilate the plant room
I05	37	Blower overcurrent (the blower has exceeded the current limit)	Check the operation of the blower (seized or excessive friction)
I07	39	Condensers overvoltage (the condensers have exceeded the max. voltage limit)	Check the mains voltage (max. 260V)
S08	40	Centrifuge short-circuit	Eliminate the short-circuit
S09	41	PC-Board short-circuit on the centrifuge output	Replace the PC-Board
S10	42	Centrifuge instant overcurrent (the centrifuge has exceeded the current limit)	Eliminate siphons in the piping or check the centrifuge operation (seized or excessive friction)
S11	43	Centrifuge time delayed overcurrent (the centrifuge has exceeded the current limit)	Eliminate siphons in the piping or check the centrifuge operation (seized or excessive friction)
I13	-	Amalgam level sensor disconnected	Connect the amalgam level sensor
I16	48	The vacuum detecting pipe is disconnected	Connect the vacuum detecting pipe to the centrifuge
I17	49	Centrifuge thermal switch switched-on	Ventilate the room

- *Important notices*
- *Transport and storage*
- *Transport of second-hand appliances*

• *Important notices*

- Appliances are guaranteed for one year from the date of sale, provided that the warranty slip is returned to the manufacturer with date of sale, retailer's and customer's name.
- Warranty and manufacturer's liability cease in case appliances are treated with products which are unsuitable or different from those recommended by the manufacturer and also in case appliances are improperly used or tampered with operations of any kind carried out by people who are not authorized by the manufacturer.
- The manufacturer, concessionaires, agents and authorized technicians are at customers' disposal for advice and assistance and to supply literature, spare parts and anything useful.
- The manufacturer reserves the right to modify the products for improvements, for technical, normative and functional reasons or for problems due to the availability of products or semi-finished products, without prior notice.
- Our **updated** manuals are available on the web site **www.cattani.it**. We recommend they are consulted especially for updates about **safety**.
- Turbo-Smart is a EEE device, therefore it is subject to the WEEE (Waste of Electrical and Electronic Equipment) regulations.

• *Transport and storage*

- Packed appliances can be transported and stored at a temperature ranging from -10 °C to +60 °C.
- Packages must be kept away from water and splashing and cannot tolerate humidity >70%.
- Packages with the same weight can be stored in piles of three only.

• *Transport of second-hand appliances*

- Before packing, we suggest to cleanse and disinfect the aspirator with Fast & Steril 3 (refer to the paragraphs "Signals and warnings" and "Routine maintenance").
- Drain all tubes and ports (including those that convey fluids from inside machine) and possible residual fluids (including disinfectant), which can damage the control panel. Remove the amalgam collection canister, add the disinfectant, place and then lock the hermetically sealed lid on the canister. Once the suction unit is dry –both externally and internally- close all of the inlets and outlets with the purpose-made caps, fit a new (and empty) amalgam collection canister to the unit, and wrap both the suction unit and control panel separately in plastic, in order to ensure that these items are waterproof.
- Place the machine into a polyethylene bag, seal and pack it in 3-layer corrugated board.



TURBO SMART

A UNIVERSAL ASPIRATOR

INDEX

Données générales de fonctionnement 50/60 Hz	50
Introduction	51
Signaux et avertissement	51
Installation et mise en marche	52
Entretien ordinaire	56
Entretien extraordinaire	57
Instructions pour naviguer dans les menus du Turbo-Smart et modifier certains paramètres	58
Notice de réglage de la communication zigbee (sans fil)	65
Description des alarmes	70
Avis importants.....	71
Transport et stockage	71
Transport des appareils usagés	71
Tables	121

- *Données générales de fonctionnement 50/60 Hz
Aspirateur pour l'usage dentaire Turbo-Smart*

Modèle	Turbo-Smart "A"	Turbo-Smart "B"
Tension nominale	230 V ~	230 V ~
Fréquence nominale	50/60 Hz	50/60 Hz
Courant nominal	7 A	9 A
Mode d'emploi	Fonctionnement continu	Fonctionnement continu
Protection contre l'humidité	Commune	Commune
Puissance absorbée maximum	1,45 kW	1,87 kW
Débit maximum	86 m ³ /h	105 m ³ /h
Dépression maximum en service continu	2000 mm H ₂ O	2000 mm H ₂ O
Vitesse de rotation	70 Hz 85 Hz	70 Hz 110 Hz
Pression sonore version sans capot	68,4 dB(A) 69 dB(A)	68,4 dB(A) 73,7 dB(A)
Pression sonore version capotée en plastique	66,4 dB(A) 67 dB(A)	66,4 dB(A) 72 dB(A)
Pression sonore version capotée pour l'intérieur	48,5 dB(A) 49,5 dB(A)	48,5 dB(A) 52,2 dB(A)
Pression sonore version capotée pour l'extérieur	54 dB(A) 55 dB(A)	54 dB(A) 58,7 dB(A)

~	Courant alternatif	IEC 417-5032
⊕	Conducteur de protection	IEC 417-5019
	Degré de protection contre les contacts directs ou indirects	IEC 60204-1
○	Ouvert (débranchement du réseau d'alimentation)	IEC 417-5008
I	Fermé (branchement au réseau d'alimentation)	IEC 417-5007

Niveau de pression sonore obtenu selon la norme ISO 3746-1979 (E).

Paramètres : r ou d = 1,5 - bruit de fond : 34 dB (A) - Instrument : Brüel & Kjær type 2232.

- *Introduction*
- *Signaux et avertissement*

- **Introduction**

La présentation ci-après a pour objectif d'illustrer l'installation et la mise en marche du Turbo-Smart et de renseigner sur les dangers et les précautions à prendre pour une bonne prévention des accidents.

Ce manuel doit être toujours disponible pendant le déballage, l'utilisation et la mise en marche du Turbo-Smart.

Sur le site internet **www.cattani.it** on peut trouver nos manuels techniques **mis à jour**.

Nous recommandons de les consulter surtout pour les mises à jour concernant la **sécurité**.

- **Signaux et avertissement**

- *Danger de décharge électrique - même le courant 230 V \sim peut être mortel.*



- *Danger biologique d'infection par des maladies épidémiques.*



- *Signal générique de danger.*



- *Protections personnelles pour gros travaux.*



- *Protections personnelles pour danger biologique.*



- *Haute température.*



- *Local interdit aux substances inflammables, corrosives ou explosives.*



- *Direction obligatoire du flux ou du sens de rotation.*



Il n'est pas toujours possible d'exprimer par un signal les avis de danger, il est donc nécessaire que l'utilisateur lise les avertissements et en tienne compte.

Ne pas respecter un signal ou un avis de danger peut entraîner des dommages aux opérateurs ou aux patients.

Ne pas retirer les protections contre les accidents ; ne pas modifier les appareils ou leur fonctionnement.

En dépit de nos efforts, il est possible que les avis de danger ne soient pas exhaustifs. Nous nous excusons auprès des utilisateurs et les prions en même temps de se protéger contre toute source de danger que nous pouvons avoir négligée et de nous en informer.

• Installation et mise en marche

• Précautions recommandées

Avant d'installer l'appareil, contrôler l'extérieur de l'emballage. Faites attention à l'étiquette shockwatch. Si elle est rouge ou si le carton a été endommagé, acceptez le matériel en vous réservant de contrôler l'appareil.

Déballer la machine selon les instructions dessinées sur l'emballage. Le carton est recyclable. Nous recommandons de l'évacuer selon les normes en vigueur. Conserver tous les bouchons plastique qui ferment les entrées et sorties de l'appareil, car doivent être utilisés pour déplacer ou transporter la machine.

L'installation des machines doit être effectuée par un technicien expert et équipé. Placer l'aspirateur dans un endroit propre, loin des sources de chaleur, de l'humidité et de la poussière. En cas d'installation à l'extérieur (balcon, véranda, jardin) il faut protéger les machines de la pluie, des éclaboussures, de l'humidité, du gel et des rayons directs du soleil.

Pour l'installation à l'extérieur nous pouvons fournir un capot spécial qui inclut : double toit isolant, protection antigel et système de ventilation avec thermostat fixe pour la régulation automatique de la température.

Dans le local technique, maintenir une température comprise entre + 5°C et + 35°C.

Les machines capotées, pour l'intérieur ou l'extérieur, peuvent être fournies avec équipement antigel. Si votre local technique doit être ventilé ou climatisé, nous vous suggérons de confier le projet à un frigoriste. Le local technique doit être interdit aux patients. Si un local semblable n'est pas disponible, il faut protéger les machines avec des capots qui ne puissent pas être enlevés facilement. Utilisez des protections et des signaux de danger de façon à éviter les contacts accidentels qui sont dangereux à cause des décharges électriques, de la possibilité (très rare mais qui ne peut pas être totalement exclue) d'incendie, d'explosion et de fuite d'air ou de liquides contaminants. Pour l'installation à l'intérieur et à l'extérieur n'employer que des capots spécialement conçus et produits par le fabricant des machines.

Il ne faut pas introduire des substances inflammables dans le local technique. Veiller qu'il n'y ait aucune possibilité de fuites de gaz. Ne pas brancher au courant des appareils endommagés ; n'utiliser ni rallonges ni prises ou fiches multiples. Avant de brancher l'appareil au courant, s'assurer que la ligne d'alimentation est conforme aux normes C.E.I. 64-8 et qu'un interrupteur thermique et un interrupteur à courant résiduel (classe A ou B) **(16A)** selon les normes EN 61008-1 sont présents. Les planchers de couleur claire, de bois, linoléum, caoutchouc ou marbre peuvent changer de couleur ou se tacher au contact des pieds antivibration **(1)**. Isoler ces derniers du plancher avec une feuille en plastique ou en autre matériau indiqué.

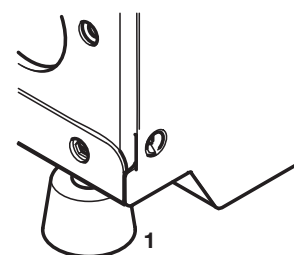
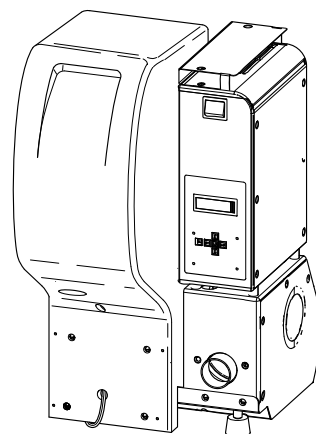
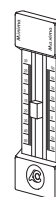
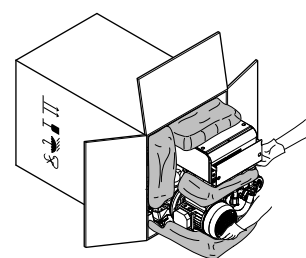

• Installation

Il est conseillé d'installer en parallèle que des machines ayant les mêmes valeurs de débit et de dépression. Avant de relier l'appareil à la canalisation du système centralisé, s'assurer que les tuyauteries d'aspiration sont propres; les débris lourds pourraient endommager l'appareil. Le tuyau en PVC (**2b**) gris clair qui est fourni avec l'appareil doit être relié au porte-tuyau (**2**) diamètre 50 mm (« entrée fluides aspirés »). L'autre extrémité du tuyau doit être reliée à la canalisation d'aspiration (**3**) qui vient des cabinets (page 54).

Le tuyau noir pour l'air expulsé (qui contient une spirale métallique et qui est résistant à la chaleur) (**4b**) doit être relié au porte-tuyau (**4**) diamètre 50 mm (« sortie air expulsé »). Relier l'autre extrémité du même tuyau au filtre antibactérien (**5**) après être passé par le silencieux (**5a**) fourni avec l'aspirateur. A la sortie du filtre antibactérien, l'air expulsé, qui est encore chaud, doit être dirigé à l'extérieur. Relier le porte tuyau (**6**) diamètre 18 mm au tuyau de vidange des liquides. Le porte-tuyau (**8**) diamètre 10 mm (vidange de sécurité) doit être relié à la vidange des liquides. Dans la version avec Hydrocyclone l'aspirateur draine les liquides par gravité, donc la vidange doit être plus basse. Les tuyaux de jonction entre la machine et le système d'aspiration et de drainage sont flexibles à fin d'amortir les petites vibrations produites par le fonctionnement de l'aspirateur. En général les tuyaux d'aspiration courent dans le plancher et près de l'aspirateur un tuyau monte d'à peu près 30 cm pour arriver au porte tuyau (**2**) (fig.A et B, page 121).

Dans le cas où Turbo-Smart est installé à l'étage au-dessous des unités dentaires, le tuyau d'aspiration ne doit pas entrer directement dans le séparateur centrifuge, quelques mètres de tuyau doivent être installés horizontalement au même niveau que la machine jusqu'à l'entrée du séparateur centrifuge (fig. B, page 121) (utiliser un tuyau flexible) qui se trouve sur un niveau plus haut. Les fluides seront reaspirés par la machine. Après l'installation, il faudra brancher le câble d'alimentation à la ligne électrique du local technique selon la norme EN 61008-1. A la fin, brancher la ligne de télécommande des utilisateurs : les bornes 19 et 20 du circuit AC80-07 (schéma de câblage AC80-07, fig. C, page 122) sont reliés à la ligne des utilisateurs (**12**) (détail 12, page 54 et fig. F, page 125), tous les unités dentaires du même système sont branchés en parallèle. S'assurer que le contact sur l'unité dentaire est sans tension (contact sec).

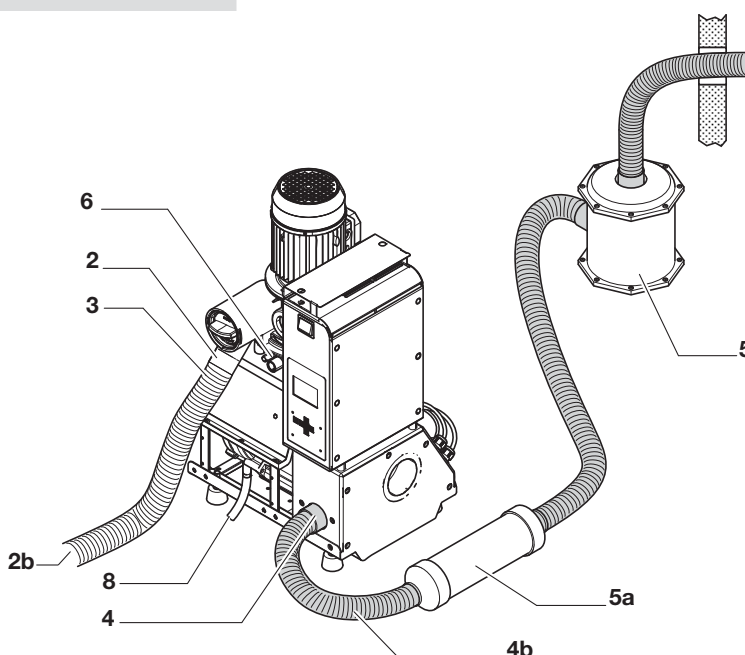
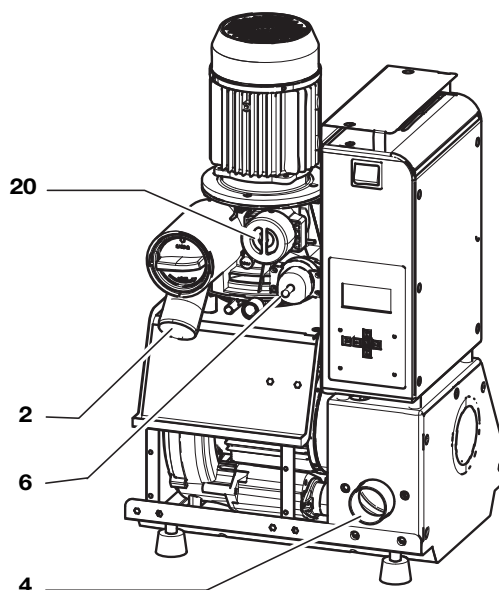

- **Installation en parallèle**

Deux ou trois aspirateurs en parallèle (fig. F) doublent ou triplent le débit, pourvu que le diamètre de la canalisation principale soit augmenté de 10 mm pour chaque aspirateur additionnel. De la même façon il faudra augmenter le diamètre des tuyauteries de l'air expulsé. Turbo-Smart est fourni avec tous les accessoires nécessaires pour l'installation en parallèle, par conséquent il ne faut ni vannes unidirectionnelles, ni boîtes de commande supplémentaires ou unités périphériques. Après avoir relié à la même canalisation principale les 2 ou trois aspirateurs installés en parallèle, brancher en parallèle les lignes des utilisateurs (**12**) qui viennent des unités dentaires. Quand vous installez les aspirateurs en parallèle, faites attention à ne pas inverser pas les câbles des bornes n°19 et n°20. Avec des aspirateurs en parallèle il peut arriver qu'un appareil s'arrête sans que les utilisateurs s'en aperçoivent. Pour éviter cet inconvénient, les bornes 8 et 9 de la boîte de commande (contact sec) permettent de déporter un signal d'alarme en dehors du local technique. Plusieurs Turbo-Smart en parallèle, quand ils fonctionnent simultanément offrent des performances meilleures et permettent d'économiser plus d'énergie. Couper le courant à un des aspirateurs ne procure pas une économie d'énergie, il diminue plutôt le rendement des machines qui restent en fonction.

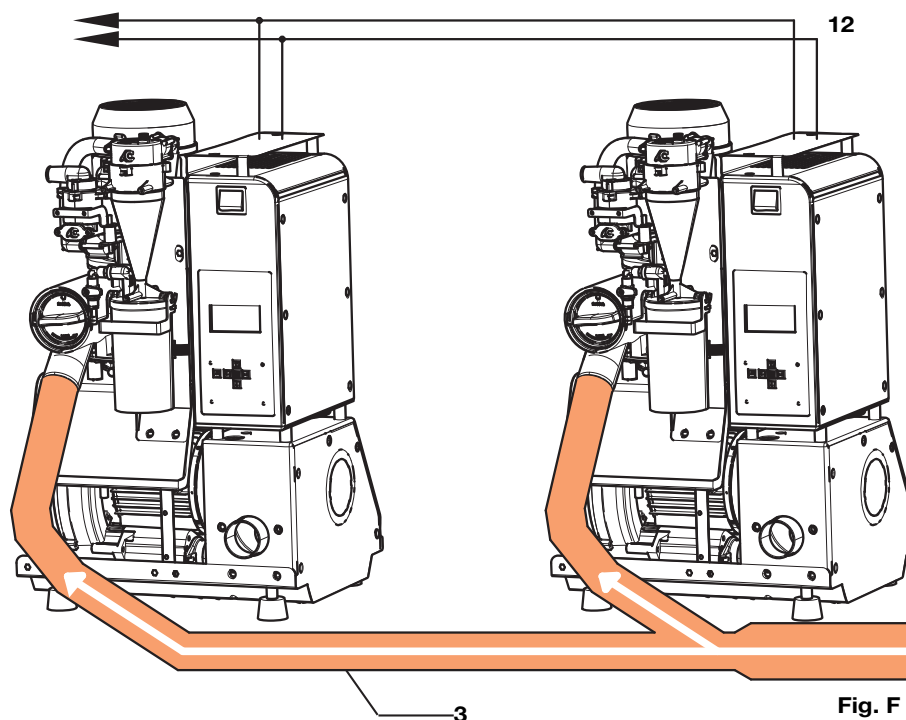

Fig. F

Draw. F

Mise en marche, essai et instruction des utilisateurs.

Lorsque l'aspirateur a été installé et branché au courant, positionner l'interrupteur sur la position ON, l'interrupteur va s'éclairer et dès qu'un des units commande l'aspiration elle se met en marche. Afin de vérifier le fonctionnement correct du Turbo-Smart, il est conseillé d'effectuer les tests dynamiques (fig. D, page 123 et Diagramme de fonctionnement du Turbo-Smart, fig.E, page 124). Pour l'instruction des utilisateurs sur l'usage et l'entretien ordinaire de l'aspirateur utiliser une machine neuve, non utilisée et donc non contaminée. Le personnel du cabinet devra être instruit à suivre sur l'écran les phases de fonctionnement du Turbo-Smart, à interpréter les avertissements de danger et à effectuer un entretien correct avec le Puli-Jet plus new avec anticalcaire (A) en utilisant le Pulse Cleaner (B) et avec les pastilles antimousse désinfectant (C).

Fonctionnement

Le moteur d'aspiration (9) (à travers le tuyau 10) crée la dépression dans le séparateur centrifuge (11). Les fluides qui viennent des units dentaires entrent dans le séparateur centrifuge (11) à travers le tuyau collecteur (2).

Le séparateur centrifuge sépare l'air des liquides : l'air est expulsé à l'extérieur à travers le tuyau (4), tandis que les liquides (dans la version du Turbo-Smart sans séparateur d'amalgame) sont évacués dans la vidange à travers le tuyau de vidange relié au porte tuyau (6).

Le séparateur centrifuge (11) se met en marche avant le moteur d'aspiration (9). Ça permet de drainer les liquides qui peuvent se déposer dans le séparateur centrifuge avant que l'aspiration soit mise en marche. En outre, quand la machine est arrêtée, un temporisateur (réglable) maintient l'aspirateur en marche pour min.10" - max.120".

Séparateur d'amalgame ISO 18

Turbo-Smart peut être fourni avec le séparateur d'amalgame « Hydrocyclone ISO 18 », qui est livré avec son manuel.

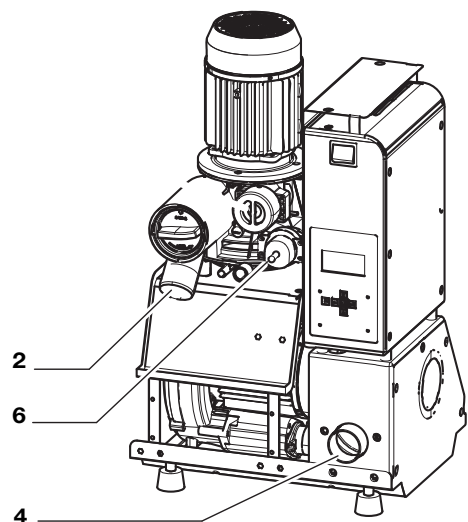
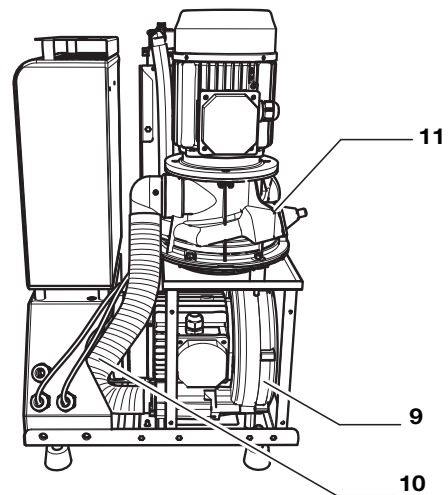
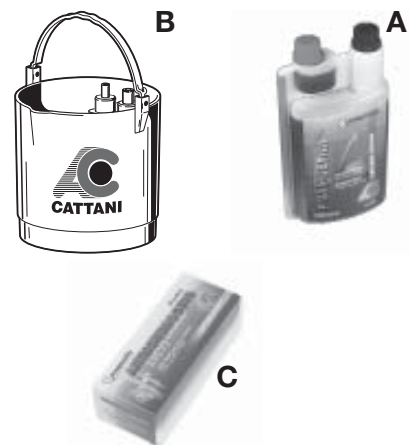

• *Entretien ordinaire*

L'entretien ordinaire doit être confié au personnel du cabinet expressément instruit.

- nous recommandons de faire attention à tous les signaux de danger et de se protéger avec lunettes, gants et tablier jetable.

Tous les jours

- vérifier sur l'écran la signalisation des alarmes éventuelles, en cas d'avis de danger, contacter le technicien.

Tous les soirs

- aspirer le soir la solution de Puli-Jet plus new **(A)** désinfectant avec anticalcaire en utilisant le Pulse Cleaner **(B)**;
- débrancher le courant avant toute intervention sur la machine.

Tous les jours

- mettre des pastilles antimousse dans les filtres des unités dentaires.

Périodiquement

- tenir le filtre de la machine propre.

De temps en temps

- vérifier qu'il ne se forme pas d'obstacles à la ventilation libre de l'aspirateur ;

- tenir le local technique libre de tout ce qui n'a rien à voir avec les machines, particulièrement des matières inflammables. Veiller qu'il n'y ait aucune possibilité de formation de mélanges corrosifs, inflammables ou explosifs.



ALLARME:
TEMPERATURA ELEVATA

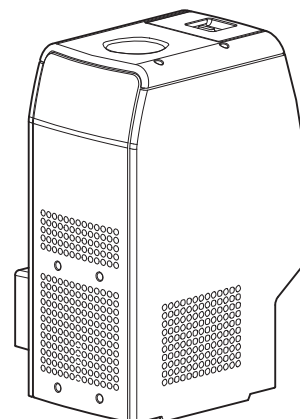
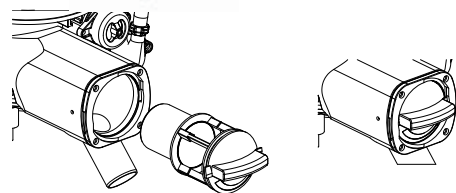
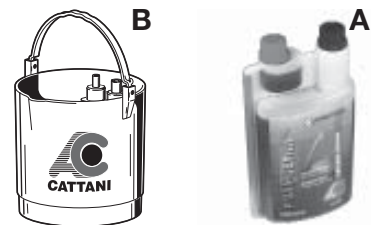

• *Entretien extraordinaire*

L'entretien extraordinaire doit être confié à un technicien formé et autorisé disposant des pièces de rechange d'origine :

- faire attention à tous les signaux de danger et se protéger avec lunettes, gants et un tablier jetable ;
- contrôler que l'entretien ordinaire ait été exécuté soigneusement et vérifier qu'on utilise les produits Magnolia ;
- avant toute intervention, laver plusieurs fois l'appareil avec du Fast & Steril 3 (D). Attendre 15 minutes pour obtenir une action désinfectante complète.

Contrôles conseillés tous les 12 mois

- vérifier les températures maximum enregistrées et tous les signaux d'alarme, intervenir selon les exigences du cas;
- contrôler le bruit de l'aspirateur, max. 72 dB (A) selon la norme 3047 (E);
- si nécessaire à l'aide d'un jet d'air sec ne dépassant pas 2 bars de pression enlever la poussière sur les composants électroniques du circuit AC80 et avec un jet d'air à 6 bars nettoyer les petits trous sur le couvercle frontal du moteur d'aspiration (15);
- contrôler l'état des tuyaux en plastique, en particulier des tuyaux sous pression de jonction entre le séparateur centrifuge (11) et l'Hydrocyclone ISO. Nous conseillons de remplacer ces tuyaux tous les 12-18 mois.

Contrôles conseillés tous les 18-24 mois

- contrôler les conditions de fonctionnement du séparateur centrifuge (11) et de la soupape de recirculation (14).

Contrôles conseillés toutes les 10.000 res de fonctionnement

- lors qu'un composant contenant une pièce en caoutchouc (joint torique ou joint d'étanchéité) est désassemblé remplacer la pièce en caoutchouc ;
- remplacer les roulements des moteurs ;
- si on constate une précarité d'entretien ou l'utilisation de produits impropres, instruire le personnel et informer le responsable du cabinet.

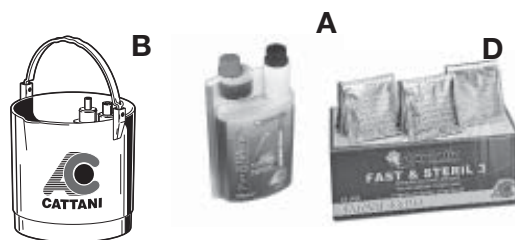

ALLARME:
TEMPERATURA ELEVATA

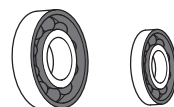
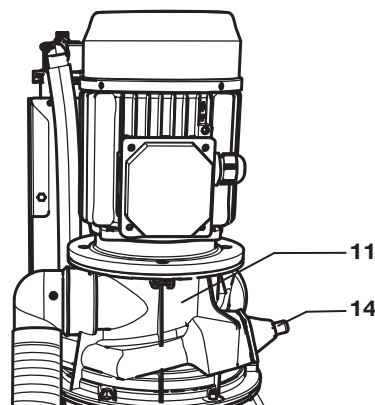
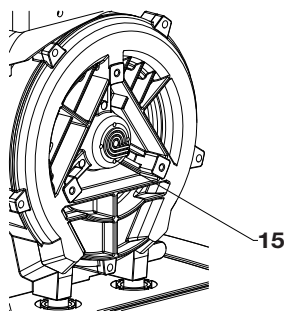

- *Instructions pour naviguer dans les menus du Turbo-Smart et modifier certains paramètres*

Menus principaux

Au démarrage du Turbo-Smart, le logo Cattani S.p.A. apparaît sur l'écran pour 10 secondes avant que le menu principal est visualisé.



Menu principal "A1"

Ce menu visualise les paramètres suivants: fréquence du courant, totalisateur horaire, température machine, présence et niveau de remplissage du séparateur d'amalgame et version du software.



Menu de contrôle "A2"

Cet écran visualise le nombre mises sous tension (Power Cycles), le nombre d'heures sous tension (Uptime), le nombre de mises en marche (Work Cycles), le nombre total d'heures de fonctionnement (Work Time), la moyenne pondérée des heures de fonctionnement du moteur d'aspiration (Aspirator) et le nombre de mises en marche du ventilateur de refroidissement (Fan Cycles).

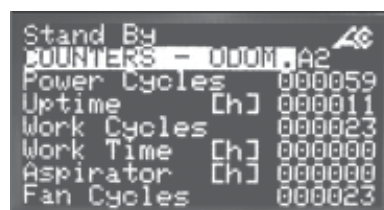

Menu événements "A3"

Ce menu visualise les derniers 10 événements ou alarmes survenus au Turbo-Smart. Les alarmes sont indiqués par un numéro; se référer au tableau à la page 70 pour les identifier.



Menu de contrôle "A2"

COUNTERS - ODOM . A2		
POWER CYCLES	000000	Nombre mises sous tension de l'aspirateur
UPTIME [h]	000000	Nombre total d'heures sous tension.
WORK CYCLES	000000	Nombre de mises en marche.
WORK TIME [h]	000000	Nombre d'heures de fonctionnement de la machine.
ASPIRATOR [h]	000000	Nombre moyen pondéré d'heures de fonctionnement du moteur d'aspiration UNI-JET 75.
FAN CYCLES	000000	Nombre de mises en marche du ventilateur de refroidissement.

Menus

Cliquer  pour accéder aux menus secondaires.

En cliquant la touche  vous entrez dans les autres menus.

Drive Status

Ce menu est accessible sans mot de passe. L'écran affiche des informations utiles sur le Turbo-Smart.

User Parameters

Insérer le mot de passe 0000123000 pour entrer dans ce menu.

Dans ce menu il est possible de régler la dépression maximum, de modifier la langue de l'écran et d'insérer le code d'activation pour passer de la version A à la version B.

System Parameters Setup

Le mot de passe 0000456000 doit être inséré pour entrer dans ce menu.

Dans ce menu il est possible de régler certains paramètres techniques comme la temporisation d'arrêt.

Factory Settings Restricted Access

Ce menu n'est pas accessible à l'utilisateur. Seulement le fabricant peut y entrer.

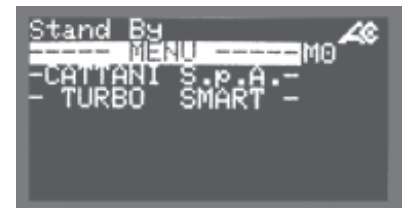

scroll down button
↓

Insérer les mots de passe





Le menu Drive Status est le seul menu accessible sans mot de passe.



Le mot de passe pour accéder au menu User Parameters est 0000123000.

Le mot de passe pour accéder au menu System Parameters Setup est 0000456000.

Quand vous vous trouvez dans le menu CATTANI S.p.A., utilisez les touches directionnelles  et 

pour faire apparaître sur l'écran le menu Access Password Access Password 0000000000.

Cliquer sur la touche Entrée  : un curseur apparaît sur le dernier zéro à droite. Utiliser la touche  pour déplacer le curseur sur le sixième zéro. En cliquant sur  le chiffre 1 apparaît. Utiliser la touche  pour déplacer le curseur sur le zéro suivant puis cliquer sur  pour faire apparaître le chiffre 2.

Utiliser la touche  pour déplacer le curseur sur le zéro suivant puis cliquer sur  pour faire apparaître le chiffre 3.

Cliquer sur la touche Entrée  pour confirmer le mot de passe. Le curseur disparaît.

Cliquer  pour retourner au menu Cattani S.p.A.

A ce point il est possible de modifier certains paramètres du menu User Parameters.

Répéter le même procédé et insérer le mot de passe 0000456000 pour entrer dans le menu System Parameters Setup.

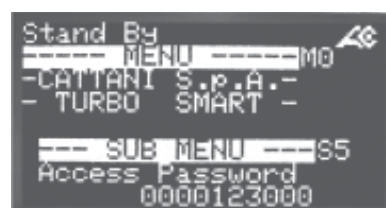
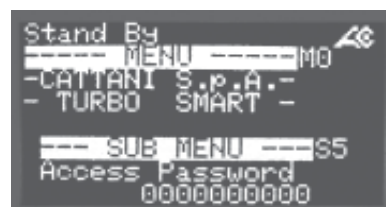
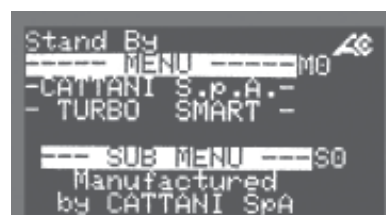
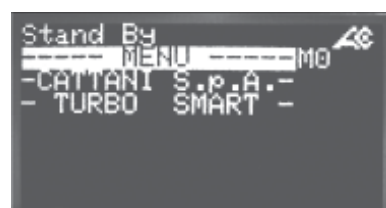
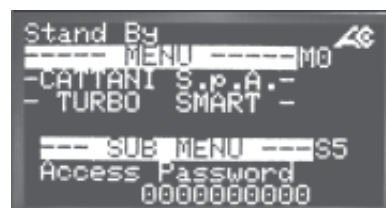

Menu Drive Status

Ce menu est accessible sans mot de passe. Il affiche différents paramètres techniques concernant les conditions de travail du Turbo-Smart en temps réel. Les informations les plus consultées sont:

Blower Output Frequency

(Fréquence de fonctionnement du moteur d'aspiration: Valeur maxi. pour la version A : 85 Hz; valeur maxi. pour la version B : 110 Hz)

Blower Output Voltage

(Tension de fonctionnement du moteur d'aspiration: valeur maxi. : 220V)

Blower Overall Current

(Intensité de fonctionnement du moteur d'aspiration: valeur maxi. pour la version A : 5,5 A, valeur maxi. pour la version B : 7,5 A)

Pump (Centrifuge) Output Frequency

(Fréquence de fonctionnement du séparateur centrifuge: valeur prédéfinie pour les versions A et B : 55 Hz)

Pump (Centrifuge) Output Voltage

(Tension de fonctionnement du séparateur centrifuge: valeur maxi.: 220V)

Pump (Centrifuge) Overall Bus Current

(Intensité de fonctionnement du séparateur centrifuge: valeur maxi. pour la version A : 5,5 A, valeur maxi. pour la version B : 7 A)

scroll down button

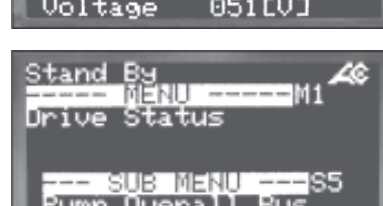
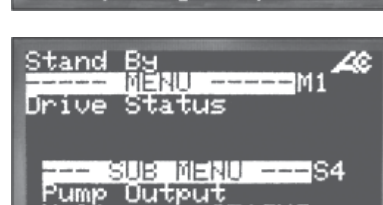
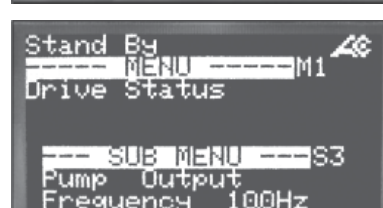
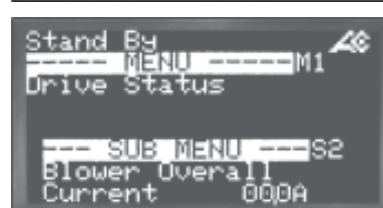
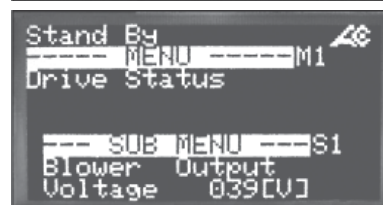
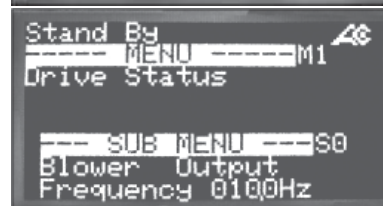

System Temperature

(Température de la boîte de commande)

Maximum Detected

(Température maximum enregistrée) (+ 58 °C : Alarme et Arrêt de l'aspirateur)

Vacuum

(Dépression)





valeur max. : 200 mbar)

Menu User Parameters

Pour entrer dans ce menu il faut insérer le mot de passe 0000123000 (suivre les instructions à la page 60).





Vacuum Set Point (Valeur de la dépression)

C'est la valeur maxi. programmée.

Cliquer sur la touche Entrée  pour faire apparaître le curseur. La valeur peut être modifiée à l'aide des touches directionnelles  . Cliquer encore sur la touche Entrée  pour confirmer et continuer.

Language (Langue)

Il est possible de choisir entre Anglais (1) ou Italien (0) pour la langue de l'écran.

Cliquer sur la touche Entrée  pour activer le curseur et utiliser les touches directionnelles   pour sélectionner 0 ou 1. Cliquer encore sur la touche Entrée  pour confirmer la modification et continuer.

scroll down button

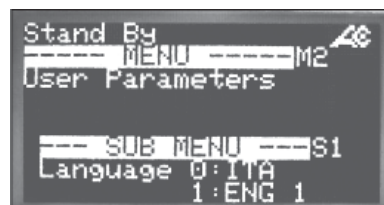
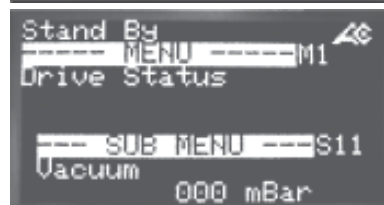
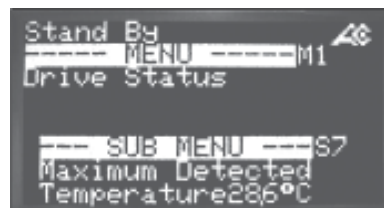
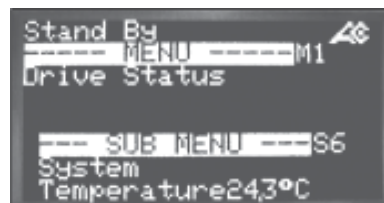





Generated Code (Code d'activation)

Ce code est créé par Cattani S.p.A. Chaque machine possède un code qui doit être fourni à Cattani S.p.A. pour obtenir le code d'activation pour passer la machine de la version A (pour 2 unités dentaires) à la version B (pour 3/4 unités dentaires).

Activation Code (Mot de passe)

C'est le code fourni par le fabricant qu'il faut l'insérer pour passer le Turbo-Smart de la version A (pour 2 unités dentaires) à la version B (pour 3/4 unités dentaires).

Cliquer encore sur la touche Entrée  pour activer le curseur. Utiliser les touches directionnelles   pour déplacer le curseur. Insérer le mot de passe à l'aide des touches   pour augmenter ou réduire la valeur.

Cliquer sur la touche Entrée  pour valider, puis utiliser la touche  pour retourner au menu User Parameters.



Menu System Parameters Setup

Pour entrer dans ce menu et/ou modifier certains paramètres il faut insérer le mot de passe 0000456000 (suivre les instructions à la page 60).

Vacuum Set Point

(Valeur de la dépression)

Valeur maxi. : 200 mbar

Pour modifier les paramètres de ce menu faire défiler les pages des sous-menus avec les touches   jusqu'à ce que le paramètre qu'on veut modifier apparaisse.

Cliquer sur la touche Entrée  pour activer le curseur et utiliser les touches directionnelles   pour afficher la valeur désirée.

Cliquer sur la touche Entrée  pour valider et continuer.

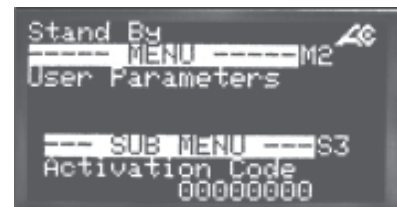
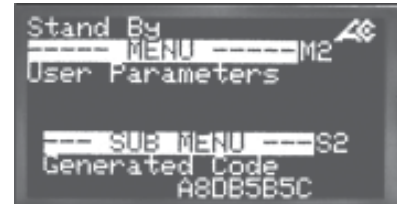

scroll down button



Blower Current Limit

(Intensité maximum)

Valeur maxi. pour la version A : 5 5 A , valeur maxi. pour la version B : 7,5 A

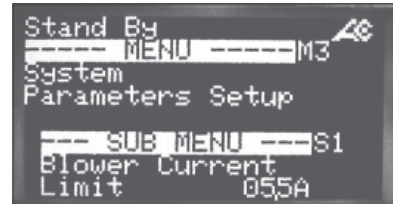

Turbo-Smart Off Delay Time

(Réglage de la temporisation d'arrêt du Turbo-Smart)

Valeur maxi. : 300 sec.

Valeur mini. : 10 sec.



Pump (Centrifuge) Off Delay Time

(Réglage de la temporisation d'arrêt du séparateur centrifuge)

Valeur maxi. : 30 sec.

Valeur mini. : 5 sec.



Control Panel Fan Off Delay Time

(Réglage de la temporisation d'arrêt du ventilateur de la boîte de commande)

Valeur prédéfinie : 300 sec.

Valeur maxi. : 1800 sec.



Running Options

(Activation ou désactivation du détecteur du niveau d'amalgame)

Sur 0 : absence séparateur amalgame

Sur 1 : presence séparateur amalgame

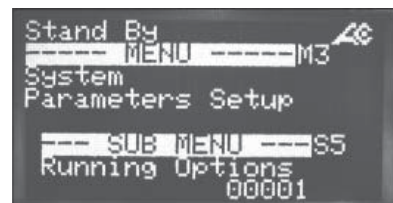

Drive Commands

Procédure permettant la calibration de certains paramètres par le fabricant.

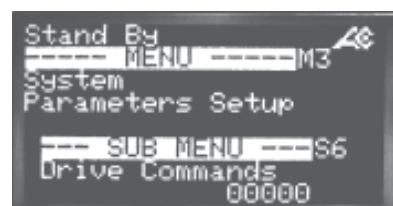

scroll down button

• Notice de réglage de la communication zigbee (sans fil)

Régler l'adresse de réseau de la machine (min. 100) (max. 110).

Introduire la clef de communication Zigbee (ETRX2 USB) dans le port USB de l'ordinateur puis lancer le programme d'affichage.

Installer le programme SMART SYSTEM MONITOR (fourni par l'entreprise Cattani) sur l'ordinateur.

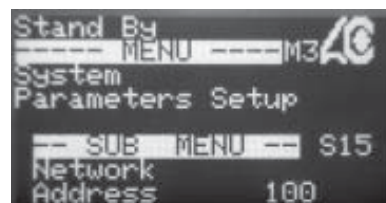

FRANÇAIS

Une fois le programme lancé, l'image de l'entreprise s'affichera pendant 10 secondes à l'écran puis le menu principal apparaîtra.



Cliquer sur le menu SERVICE afin d'entrer dans la page de recherche des dispositifs.



Cliquer sur la recherche des dispositifs disponibles. Le programme lance la recherche ; cette opération peut durer quelques secondes.

Une fois la recherche achevée, les différentes machines disponibles s'affichent avec le code qui a été généré. Il peut être nécessaire de réitérer cette opération plusieurs fois.

Dès que le programme aura trouvé les dispositifs disponibles, revenir à la page d'accueil afin d'afficher les paramètres.

Le menu déroulant permet de choisir quel Turbo Smart afficher.

Dès lors, il est possible d'afficher les paramètres de fonction.

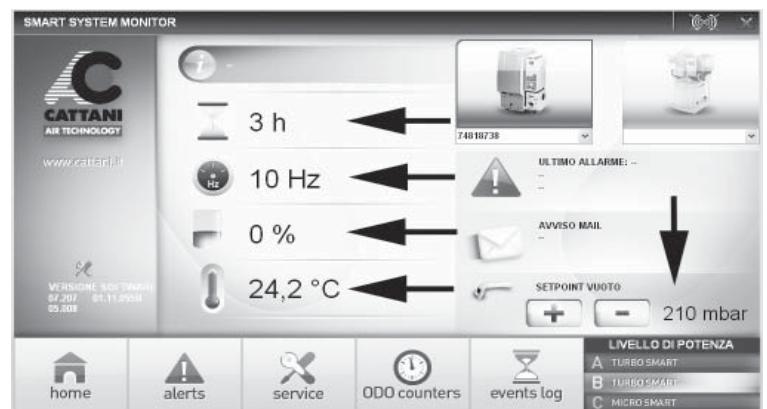
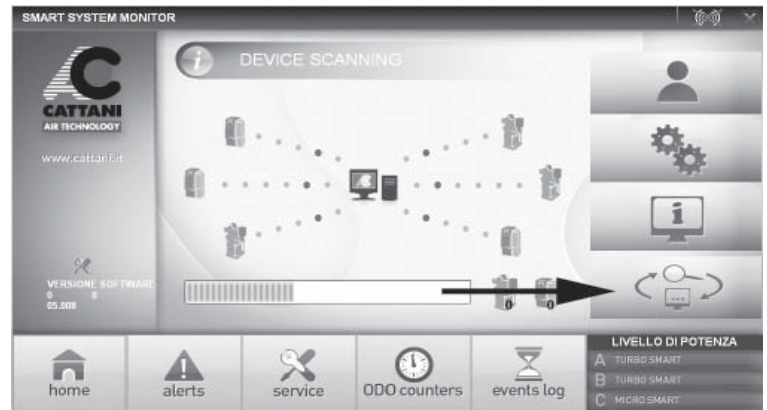

Cliquer sur l'icône SERVICE pour accéder aux trois menus différents : l'un est en accès libre et les deux autres sont protégés par un mot de passe.

Pour entrer dans le menu PARAMÈTRES USAGER, saisir le mot de passe 123000 puis valider avec OK.

Ce menu permet de modifier la langue, de choisir le niveau de pression souhaité et de transformer la machine d'un aspirateur pour 2 fauteuils en un aspirateur pour 4 fauteuils grâce à un code d'activation.

Pour entrer dans le menu REGLAGES DONNÉES DU SYSTÈME, saisir le mot de passe 456000 puis valider avec OK.



Ce menu technique rassemble tous les paramètres du Turbo Smart et permet de les modifier.

Le menu ÉTAT INVERSEUR n'est pas protégé par un mot de passe et permet d'afficher les paramètres de fonction de la machine alors qu'elle fonctionne.

Depuis le menu principal, cliquer sur l'icône courriel pour saisir les données comme l'adresse du médecin et du technicien à qui adresser les messages d'alarme.

En cas d'anomalie, une alarme s'affiche à l'écran et un courriel est envoyé au technicien responsable.



Les alarmes s'étant déclenchées pendant la journée sont affichées avec un code d'erreur et leur description figure dans le dossier ALERTS.

Le dossier EVENT LOG permet de consulter l'historique des alarmes survenues sur la machine durant toute sa période de fonctionnement.

Le menu ODO COUNTERS mémorise les cycles de déclenchement.

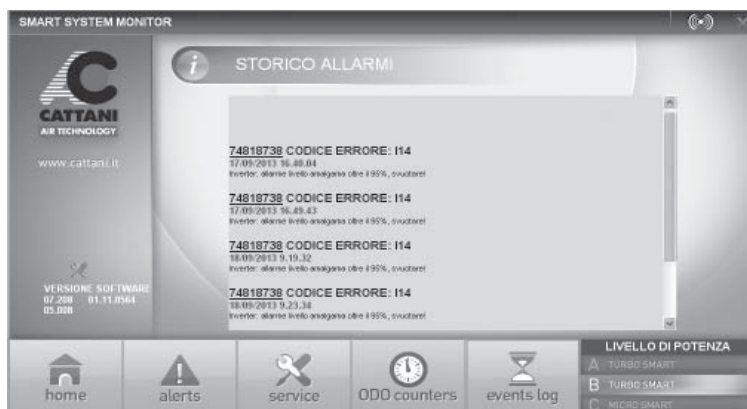

FRANÇAIS

• Description des alarmes

Code Alarme		DESCRIPTION	SOLUTION
AC80 AC80-07			
00	0	Alarme mémoire Microcontroller	Contacteur le technicien
I14	2	Niveau Amalgame > 95%	Remplacer le conteneur d'amalgame le plus tôt possible
I15	3	Niveau Amalgame > 100%	Remplacer le conteneur d'amalgame
I00	32	Alarme mémoire Microcontroller	Contacteur le technicien
I01	33	Court-circuit dû à un des deux moteurs	Contrôler d'où vient le court-circuit et l'éliminer
I02	34	Court-circuit avant le démarrage des moteurs	Contacteur le technicien (changer la platine AC 80-07)
I03	35	Les condensateurs n'ont pas été chargés	Contacteur le technicien (changer la platine AC 80-07)
I04	36	Température trop élevée (la température a dépassé la limite maxi. consentie)	Ventiler le local technique
I05	37	Surconsommation du moteur d'aspiration	Contrôler le fonctionnement du moteur d'aspiration (blocage ou friction excessive)
I07	39	Surtension des condensateurs (les condensateurs ont dépassé la limite maxi. de tension)	Contrôler la tension de la ligne d'alimentation (maxi. 260V)
S08	40	Court-circuit de la centrifugeuse	Éliminer le court-circuit
S09	41	Court-circuit de la platine sur la sortie de la centrifuge	Remplacer la platine
S10	42	Surconsommation instantanée de la centrifugeuse (la centrifugeuse a dépassé la limite consentie)	Éliminer les siphons sur les tuyauteries ou vérifier le fonctionnement de la centrifugeuse (blocage ou friction excessive)
S11	43	Surconsommation prolongée de la centrifugeuse (la centrifugeuse a dépassé la limite consentie)	Éliminer les siphons sur les tuyauteries ou vérifier le fonctionnement de la centrifugeuse (blocage ou friction excessive)
I13	-	Le détecteur du niveau d'amalgame n'est pas relié	Relier le détecteur du niveau d'amalgame
I16	48	Le tuyau de détection de dépression n'est pas relié	Relier le tuyau de détection de dépression à la centrifugeuse
I17	49	Sécurité thermique centrifugeuse: température trop élevée ou trop basse (gel)	Rétablir dans le local une température comprise entre +5°C et +40°C

- *Avis importants*
- *Transport et stockage*
- *Transport des appareils usagés*

• *Avis importants*

- Les équipements sont garantis pendant un an après la date de vente, à condition que la fiche de garantie correctement remplie (date de vente, nom du vendeur, nom de l'utilisateur) soit retournée au fabricant.
- La garantie et la responsabilité du fabricant cessent lorsque les équipements sont traités avec des produits impropres ou différents de ceux recommandés par le fabricant, lorsque les équipements sont mal employés ou altérés par toute opération effectuée par des personnes non autorisées par le fabricant.
- Le fabricant, les concessionnaires, les agents et les techniciens autorisés sont à disposition pour tous conseils, renseignements et pour fournir la documentation, les pièces de rechange et tout autre renseignement utile.
- Le fabricant se réserve le droit de modifier sa production sans préavis en fonction des progrès techniques, des nécessités fonctionnelles, des nouvelles normes et de la difficulté concernant la disponibilité des produits ou des produits semi-finis sur le marché.
- Sur le site internet **www.cattani.it** on peut trouver nos manuels techniques **mis à jour**. Nous recommandons de les consulter surtout pour les mises à jour concernant la **sécurité**.
- Turbo-Smart est un appareil EEE, donc soumis à la législation DEEE (Déchets d'Équipements Électriques et Électroniques).

• *Transport et stockage*

- Températures extrêmes de transport et de stockage des équipements emballés : de - 10 °C à + 60 °C.
- Les colis ne doivent pas être exposés à l'eau ou aux éclaboussures et doivent être stockés dans un endroit où le taux d'humidité ne dépasse pas 70%.
- On peut superposer seulement trois colis ayant le même poids.

• *Transport des appareils usagés*

- Avant d'emballer les appareils, nous conseillons de nettoyer et désinfecter l'aspirateur avec Fast & Steril 3 (voir paragraphes: " Signaux et avertissement" et "Entretien ordinaire").
- Vider tous les tuyaux et raccords (même ceux incorporés dans la machine) et les fluides restants (y compris le liquide désinfectant qui pourraient endommager les parties électroniques. Retirer la cassette d'amalgame, ajouter le désinfectant, refermer la cassette avec le couvercle hermétique. Lorsque la machine est sèche (extérieur et intérieur), fermer toutes les entrées et sortie avec les bouchons plastiques. Mettre une cassette d'amalgame neuve et envelopper séparément dans un plastique étanche la partie mécanique et la boîte de commande électronique.
- Enfermer l'appareil dans un sac en polyéthylène et l'emballer dans un carton triple cannelure.



TURBO SMART

A UNIVERSAL ASPIRATOR

INHALTSVERZEICHNIS

Allgemeine Betriebsdaten 50/60 Hz	74
Einleitung	75
Signale und Hinweise	75
Montage und Inbetriebnahme	76
Ordentliche Wartung	80
Außerordentliche Wartung	81
Anleitung zum Steuern der Turbo-Smarts Menüs und zum Abändern von Parametern...	82
Anweisungen für das Einstellen der zigBee-Kommunikation (drahtlos)	89
Alarmbeschreibung	94
Wichtige Hinweise	95
Transport und Lagerung	95
Transport von Gebrauchtgerten	95
Tafeln	121

- *Allgemeine Betriebsdaten 50/60 Hz Saugmaschine für die Zahnarztpraxis Turbo-Smart*

Modell	Turbo-Smart "A"	Turbo-Smart "B"
Nennspannung	230 V ~	230 V ~
Nennfrequenz	50/60 Hz	50/60 Hz
Nennstrom	7 A	9 A
Betriebsweise	Dauerbetrieb	Dauerbetrieb
Schutz gegen Feuchtigkeit	normal	normal
Höchstaufnahme	1,45 kW	1,87 kW
Höchstdurchsatz	86 m ³ /h	105 m ³ /h
Max. Förderhöhe bei Dauerbetrieb	2000 mm H ₂ O	2000 mm H ₂ O
Drehzahl	70 Hz 85 Hz	70 Hz 110 Hz
Schalldruckpegel ohne Gehäuse	68,4 dB(A) 69 dB(A)	68,4 dB(A) 73,7 dB(A)
Schalldruckpegel mit Gehäuse aus Kunststoff	66,4 dB(A) 67 dB(A)	66,4 dB(A) 72 dB(A)
Schalldruckpegel mit Gehäuse für Innenmontage	48,5 dB(A) 49,5 dB(A)	48,5 dB(A) 52,2 dB(A)
Schalldruckpegel mit Gehäuse für Außenmontage	54 dB(A) 55 dB(A)	54 dB(A) 58,7 dB(A)

~	Wechselstrom	IEC 417-5032
⊕	Schutzerdung	IEC 417-5019
	Schutzgrad gegen direkte und indirekte Berührung	IEC 60204-1
○	Offen (Stromversorgung unterbrochen)	IEC 417-5008
I	Geschlossen (Stromversorgung angeschlossen)	IEC 417-5007

Schalldruckpegel gemäß ISO-Norm 3746-1979 (E) gemessen.
 Parameter: r oder d= 1,5 - Hintergrundgeräusch: 34 dB (A) - Messgerät: Brüel & Kjær Typ 2232.

* * Schalldruckpegel nach Höchstgeschwindigkeit und Höchstförderhöhe gemessen.

- *Einleitung*
- *Signale und Hinweise*

- *Einleitung*

Diese Präsentation dient der Darstellung der Montage und der Inbetriebnahme der Anlage und der Information bezüglich der Gefahren und der nützlichen Vorsichtsmaßnahmen.

Während des Auspackens, des Betriebes, der Montage und der Inbetriebnahme des Turbo-Smarts sollte das Handbuch jederzeit als Ratgeber verfügbar sein.

Auf der Internetseite www.cattani.it finden Sie unsere **aktualisierten** Handbücher.

Wir empfehlen, diese Handbücher und insbesondere die enthaltenen Aktualisierungen betreffend **Sicherheit** zu lesen.

- *Signale und Hinweise*

- *Stromschlaggefahr, auch 230 V \sim können tödlich sein!*



- *Biologisches Risiko, Infektionen durch ansteckende Krankheiten.*



- *Allgemeines Gefahrensignal.*



- *Personenschutzvorrichtungen für anstrengende Arbeiten.*



- *Personenschutzvorrichtungen für ansteckende Krankheiten.*



- *Hohe Temperaturen.*



- *Im Maschinenraum dürfen keine entflammaren, korrosiven oder explosiven Materialien stehen.*



- *Vorgeschriebene Fluss- und Drehrichtung.*



Nicht immer kann mit einem Signal der erforderliche Gefahrenhinweis gegeben werden, daher muss der Benutzer die Hinweise aufmerksam lesen und diese beachten.

Das Nichteinhalten eines Signals oder eines Gefahrenhinweises kann dem Benutzer oder dem Patienten Schaden zufügen.

Die Schutzvorrichtungen dürfen nicht abmontiert, die Maschinen und ihre Betriebsweise nicht verändert werden.

Trotz unserer Bemühungen könnten die Hinweise nicht vollständig sein, daher bitten wir den Anwender, selbst auf uns möglicherweise entgangene Gefahrenquellen zu achten und uns diese mitzuteilen.

• Montage und Inbetriebnahme

• Empfohlene Vorsichtsmaßnahmen

Vor dem Auspacken, die Außenseite der Verpackung kontrollieren. Im Falle, dass der Shockwatch-Indikator rot geworden ist oder die Verpackung beschädigt wurde, das Material annehmen, sich aber die Möglichkeit vorbehalten, das Gerät zu kontrollieren. Die Maschine anhand der auf der Verpackung abgebildeten Anweisungen auspacken. Wir empfehlen, den Karton ordnungsgemäß zu entsorgen (er ist wiederverwertbar). Die Kunststoffabdeckungen, die alle Ein- und Auslässe des Gerätes bedecken, aufbewahren, da sie bei Bewegung oder Transport der Maschine benutzt werden müssen.

Die Montage des Gerätes muss von einem Techniker montiert werden, der über die geeigneten Werkzeuge verfügt und erfahren ist. Die Saugmaschine muss an einem sauberen Ort, fern von Wärmequellen, Feuchtigkeit und Staub, aufgestellt werden. Die im Freien (auf einem Balkon oder einer Veranda, im Garten) aufgestellten Maschinen vor Regen, Flüssigkeitsspritzern, Feuchtigkeit, Frost und direkter Sonneneinstrahlung schützen. Für die Außenmontage kann die Maschine mit einem speziellen Gehäuse geliefert werden, das mit doppeltem Isolierdach, Frostschutzanlage und Belüftungsanlage ausgestattet ist (letztere sind beide mit festem Thermostat für die automatische Temperaturregelung versehen). Es muss sichergestellt werden, dass die Lufttemperatur im Maschinenraum zwischen mindestens +5 °C und höchstens +35 °C liegt. Die Maschinen mit Gehäuse (für Außen- und Innen-Montage) können mit Frostschutzanlage geliefert werden. Für die Entwicklung einer Belüftungs- oder Klimaanlage des Maschinenraums, einen Installateur kontaktieren. Die Patienten dürfen zum Maschinenraum keinen Zugang haben. Falls ein solcher Raum nicht verfügbar ist, müssen die Maschinen durch ein geeignetes Schutzgehäuse geschützt werden, das nicht leicht zu entfernen ist. Schutzmaßnahmen und Gefahrenschilder vorbereiten, um Stromschläge, Brände, Explosionen (eine unwahrscheinliche aber nicht ausschließbare Möglichkeit) und das Austreten von kontaminierter Luft oder von Flüssigkeiten zu vermeiden. Es sind ausschließlich die vom Hersteller der Maschine entwickelten Schutzgehäuse für Außen- und Innen-Montage zu verwenden.

Im Maschinenraum dürfen keine entflammaren Materialien stehen. Überwachen Sie stets, dass es keine Möglichkeit für das Gasaustreten gibt. Niemals ein beschädigtes Gerät an das Stromnetz anschließen. Keine Verlängerungen und Doppelstecker/-steckdosen verwenden. Bevor das Gerät mit der Stromversorgung verbunden wird, überprüfen Sie, dass das Stromnetz die Normen CEI 64-8 erfüllt und dass es einen Motorschutzschalter und einen Fehlerstromschutzschalter (Klasse A oder B) (16A) gemäß den Normen EN 61008-1 gibt. Heller Bodenbelag aus Holz, Linoleum, Gummi oder Marmor kann beim Kontakt mit dem Vibrationsschutz aus Gummi (1) seine Farbe ändern oder dunkle Flecken bekommen. Daher ist eine Kunststoffunterlage oder ein anderes für diesen Zweck geeignetes Produkt zwischen Vibrationsschutz und Boden zu verwenden, um den Bodenbelag vor Abriebspuren zu schützen.

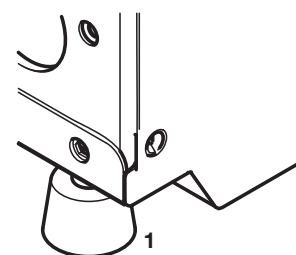
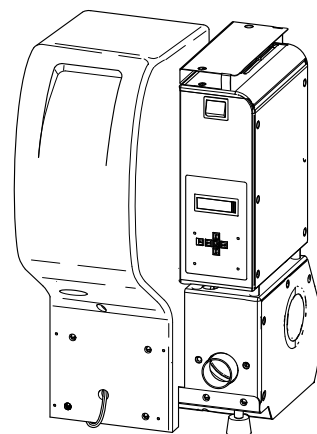
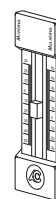
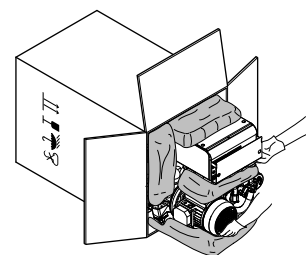

• Montage

Bevor das Gerät mit der Rohrleitung der Zentralanlage verbunden wird, ist sicherzustellen, dass die Saugleitungen sauber sind, denn schwere Fremdkörper könnten zu einer Beschädigung des Gerätes führen.

Das mit der Saugmaschine gelieferte hellgraue PVC-Saugrohr (2b) muss mit dem 50 mm Ø Rohrträger (2) („Saugleitung“) verbunden werden. Das Ende desselben Saugrohres muss mit der aus den Dentaleinheiten kommenden Saugleitung (3) verbunden werden (Seite 78).

Den schwarzen temperaturresistenten Luftauslass (4b) (mit Metallspirale) mit dem 50 mm Ø Rohrträger („Absaugguteinlauf“) (4) verbinden. Das andere Ende des Rohrs mit dem antibakteriellen Filter (5) - möglicherweise durch dem gelieferten Schalldämpfer (5a) - verbinden. Am Ausgang des antibakteriellen Filters muss die noch warme ausgetragene Luft ins Freie abgelassen werden. Verbinden Sie auch den 18 mm Ø Rohrträger (6) mit dem Flüssigkeitsabfluss. In der mit Hydrozyklon ausgestatteten Version lässt die Saugmaschine das Sekret aufgrund ihrer Schwere nur in den Abfluss. Die Flüssigkeit kann niemals nach oben austreten. Verbinden Sie den 10 mm Ø Rohrträger (8) („Notüberlaufventil“) mit dem Flüssigkeitsabflussrohr. Die Leitung zwischen der Maschine und der Absaug- und Abflussanlage ist biegsam, um die Vibrationen der Saugmaschine zu dämpfen. Gewöhnlich geht die Saugleitung durch den Fußboden in der Nähe der Saugmaschine sie steigt um 30 cm, um bis zum Rohrträger (2) hinaufzureichen (Abb. A und B, Seite 121).

Auch im Falle, dass der Turbo-Smart auf einem tieferen Stockwerk als die Dentaleinheiten installiert ist, muss die Saugleitung nicht senkrecht in den Zentrifugalabscheider eintreten. Lieber einige Meter Rohr horizontal auf dieselbe Fläche der Maschine verlegen und ein biegsameres Rohr in den Eingang des zentrifugalen Abscheiders stecken (Der zentrifugale Abscheider ist auf einer höherer Fläche) (Abb.B, Seite 121). Die abgesaugte Flüssigkeit wird von der Saugmaschine abgesaugt. Nach der Montage ist das Versorgungskabel an das Stromnetz nach der Norm EN 61008-1 anzuschließen. Zuletzt die Niederspannungsleitung des Benutzers schließen: die Klemme 19 und 20 der Platine AC80-07 (Abb.C „AC80-07 wiring diagram“, Seite 122) und die Benutzerleitung (12) (Det.12, Seite 78 und Abb. F, Seite 125), die alle Dentaleinheiten derselben Anlage mit Parallelverbindungen speist. Es ist sicherzustellen, dass der Kontakt auf der Dentaleinheit sauber ist (sauberer Kontakt ohne Spannung).

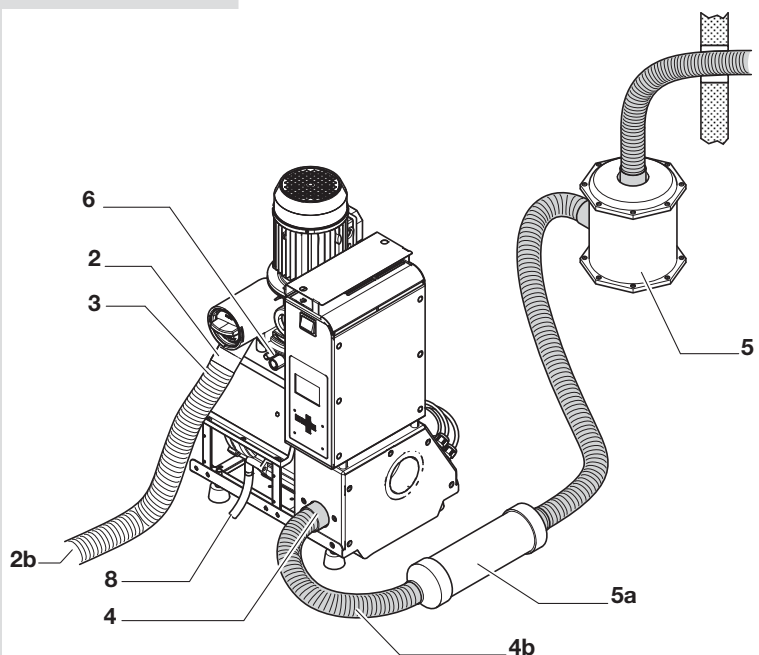
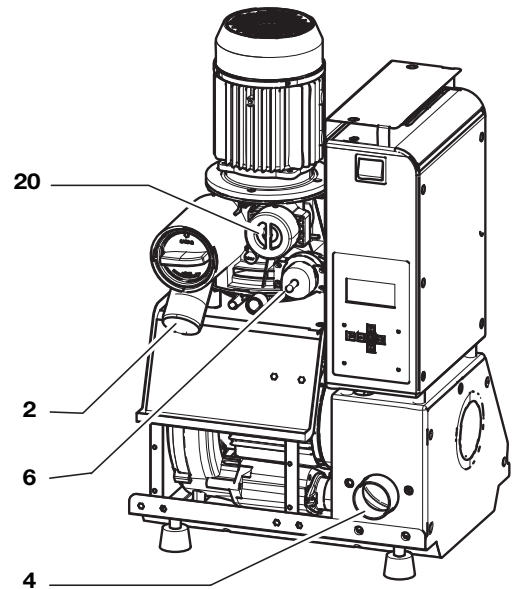

- **Parallelmontage**

Es ist empfehlenswert, nur Maschinen mit dem gleichen Durchfluss und Unterdruckwert parallel zu installieren. Zwei oder drei parallel geschaltete Turbo-Smart (Abb.F) verdoppeln oder verdreifachen den Durchsatz unter der Bedingung, dass die Weite der Hauptleitung von 10 cm für jede ergänzende Saugmaschine vergrößert wird. Auf dieselbe Weise muss die Weite der Leitung der ausgetragenen Luft vergrößert werden. Der Turbo-Smart wird mit allen notwendigen Zubehörteilen für die Parallelmontage geliefert, deshalb braucht man keine Rückschlagventile, Ergänzungsplatinen oder periphere Einheiten. Nach der Verbindung von 2 oder 3 Turbo-Smart mit derselben Hauptleitung, müssen die aus den verschiedenen Dentaleinheiten kommenden Benutzerkabel (**12**) parallel verbunden werden. Bei der Parallelmontage darauf achten, die Kabel der Klemmen n°19 mit den Kabeln der Klemmen n°20 nicht umzukehren. Mit mehreren parallel geschalteten Turbo-Smarts kann es passieren, dass ein Gerät zum Stillstand kommt, ohne dass die Benutzer es bemerken. Um diese Unannehmlichkeit zu beseitigen, erlauben die Klemmen n°8 und 9 der Platine (Potentialfreien Kontakt) ferner ein Fernblinklichtanzeigeelement zu installieren. Die parallel geschalteten Turbo-Smarts bieten eine bessere Leistung. Wann Sie unabhängig von der Nachfrage gleichzeitig arbeiten, sparen Sie Energie. Wenn man bei einer Saugmaschine die Stromversorgung unterbricht, spart man keine Energie, sondern die Leistung der Saugmaschine, die in Betrieb bleibt, wird vermindert.

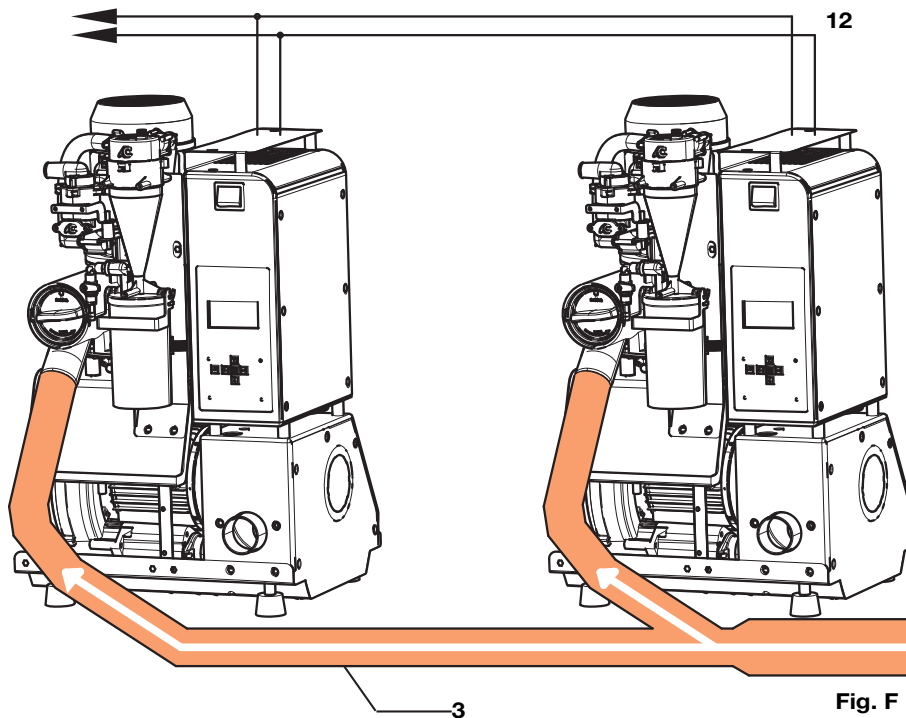

Fig. F

Draw. F

Inbetriebnahme, Abnahme und Bildung des Personals

Nach der Montage und dem Anschluss der Absauganlage wird der Netzschalter auf ON gestellt. Die im Schalter unten angebrachte Lampe schaltet sich ein und bei Übertragung des Signals von einer der angeschlossenen Dentaleinheiten setzt der Saugbetrieb ein. Um den Betrieb des Turbo-Smarts zu überprüfen, ist es ratsam dynamische Tests durchzuführen (Richten Sie sich nach der Abb. D auf Seite 123 und dem Turbo-Smart Arbeitsdiagramm - Abb. E, Seite 124). Die Ausbildung des Personals bezüglich des Gebrauchs und der ordentlichen Wartung der Absauganlage muss mit einer noch nicht verwendeten und folglich noch nicht kontaminierten neuen Maschine durchgeführt werden. Das Praxispersonal lehren, die Betriebsphasen des Turbo-Smarts auf dem Display zu verfolgen, die Warnhinweise zu erkennen und eine gute ordentliche Wartung mit Puli-Jet plus new mit Entkalkungsmittel **(A)** - Pulse Cleaner **(B)** ist zu verwenden - und Antischaumtabletten desinfektionsmittel **(C)** durchzuführen.

Betrieb

Die Absauggruppe **9** (durch das Rohr **10**) schafft das Vakuum im Zentrifugalabscheider **(11)**. Die aus den Dentaleinheiten kommende Flüssigkeit wird durch die Sammelleitung **(2)** dem Zentrifugalabscheider **(11)** zugeführt. Der Zentrifugalabscheider trennt die Luft von der Flüssigkeit: die Luft wird ins Freie durch ein Rohr **(4)** abgelassen, während die Flüssigkeit durch das mit dem Rohrträger **(6)** verbundene Abflussrohr dem Abfluss zugeführt wird.

Der Abscheider **(11)** startet vor der Absauggruppe **(9)**. Dadurch wird vor dem Starten der Absaugung Sekret abgelassen, welches sich im Abscheider gesammelt haben kann. Außerdem hält ein Zeitschalter (regulierbar) den Motor für min. 10 - max. 120 Sekunden am Laufen, wenn die Maschine ausgeschaltet wird.

Amalgamabscheider ISO 18

Auf Anfrage liefern wir den Turbo-Smart auch mit dem Amalgamabscheider „Hydrozyklon ISO 18“ (komplett mit Gebrauchsanweisung).

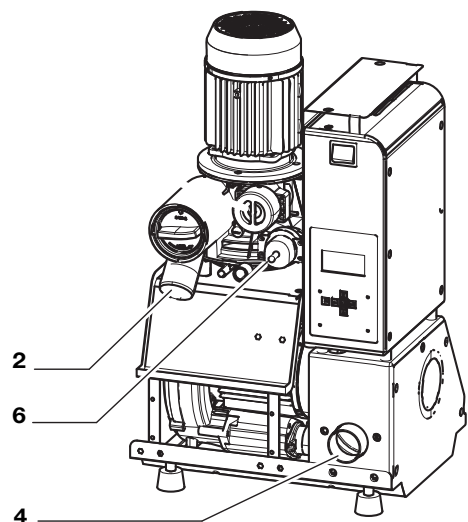
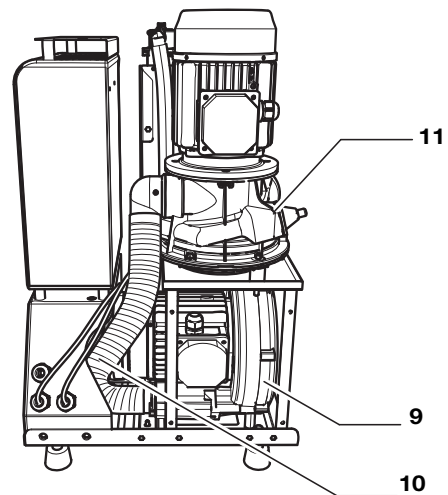
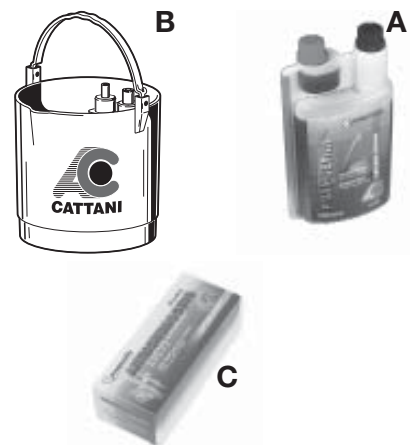

• *Ordentliche Wartung*

Die ordentliche Wartung muss entsprechend eingewiesenem Praxispersonal anvertraut werden.

- Wir bitten, auf alle Warnhinweise besonders zu achten und sich mit Schutzbrille, Handschuhen und Einwegschrürze zu schützen.

Taglich

- Das Display auf eventuelle Alarmmeldungen kontrollieren. Bei Warnhinweisen den Techniker kontaktieren.

Am Abend

- Eine Puli-Jet plus new Desinfektionsmittellosung mit Entkalkungsmittel **(A)** ansaugen (Pulse Cleaner **(B)** ist zu verwenden);
- Vor jedem Eingriff am Gerat ist die Stromversorgung zu unterbrechen.

Taglich

- Die Antischaumtabletten an den Filtern des Behandlungsstuhls anbringen.

Periodisch

- Den Filter der Absauganlage reinigen.

Gelegentlich

- Kontrollieren, dass die Beluftung des Absauggerats nicht behindert wird;
- Im Maschinenraum darf nichts stehen, was nicht zur Maschine gehort; dies gilt besonders fur entflammbare Materialien. Uberwachen Sie stets, dass sich keine korrosiven, entflammbaren oder explosiven Gemische bilden.



ALLARME:
TEMPERATURA ELEVATA

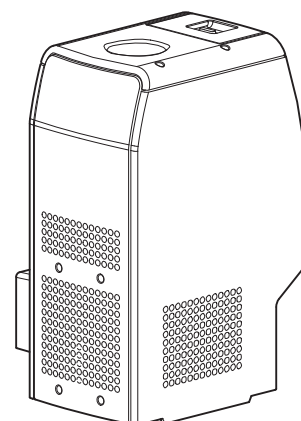
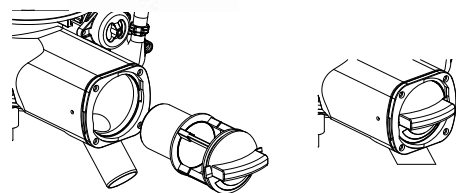
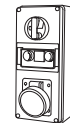
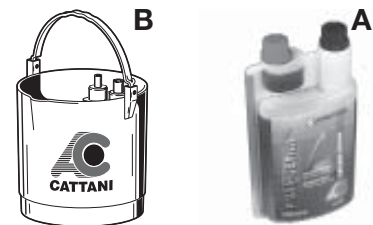

• Außerordentliche Wartung

Mit der außerordentlichen Wartung ist ein kompetenter Techniker zu beauftragen, der über Originalersatzteile verfügt:

- Auf alle Warnhinweise besonders achten und sich mit Schutzbrille, Handschuhen und Einwegschürze schützen;
- Den Zustand der ordentlichen Wartung überprüfen und sicherstellen, dass Magnolia-Produkte verwendet werden;
- Vor jedem Eingriff am Gerät sind einige Waschgänge mit Fast & Steril 3 (D) durchzuführen (15 Minuten für eine komplette Desinfektionswirkung warten).

Alle 12 Monate

- Auf dem Display die aufgezeichneten Höchsttemperaturen und Alarmsignale überprüfen. Eingreifen, wenn nötig;
- Die Betriebsgeräusche der Absauganlage überprüfen, max.72 dB gemäß der Norm 3047 (E);
- Wenn nötig mit einem trockenen Druckluftstrahl (der Druck darf 2 bar nicht überschreiten) die elektronischen Bauteile der Platine AC80 entstauben. Mit einem trockenen Druckluftstrahl von 6 bar sind auch die kleinen Löcher auf der Frontabdeckung des Saugaggregats (15) zu reinigen;
- Den Zustand der Kunststoffschläuche überprüfen, besonders die unter Druck stehenden Schläuche, die den Zentrifugalabscheider und den Hydrozyklon ISO verbinden. Wir empfehlen, diese Schläuche alle 12 - 18 Monate zu ersetzen.

Alle 18-24 Monate

- Die Betriebsbedingungen des Zentrifugalabscheiders (11) und des Überdruckventils (14) überprüfen.

Alle 10.000 Betriebsstunden

- Bei Demontage eines Geräteteils sind die dementsprechenden Dichtungsringe oder Dichtungen auszutauschen;
- Die Lager der Motoren ersetzen;
- Falls festgestellt wird, dass die ordentliche Wartung nicht korrekt / gar nicht durchgeführt wird oder ungeeignete Produkte verwendet werden, das Personal anweisen und den Praxisverantwortlichen informieren.

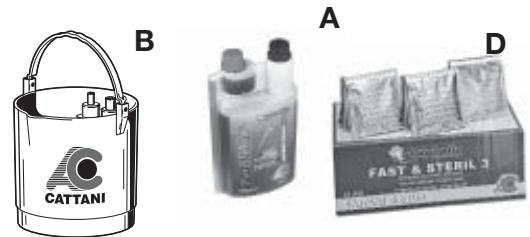

ALLARME:
TEMPERATURA ELEVATA

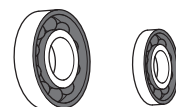
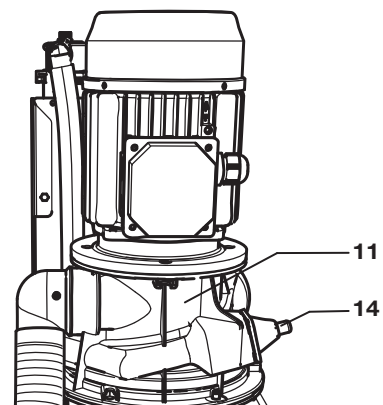
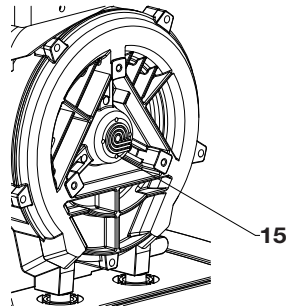

• Anleitung zum Steuern der Turbo-Smarts Menüs und zum Abändern von Parametern

Hauptmenüs

Wenn der Turbo-Smart angeschaltet wird, zeigt das Display für 10 Sekunden das CATTANI-Logo. Danach erscheint das Hauptmenü.



Hauptmenü "A1"

Dieses Menü zeigt einige Parameter wie: Frequenz, Absaugaktivierungszeit, Temperatur, Abwesenheit des Amalgambehälters und System-softwareversion.



Systemmenü "A2"

Das Display zeigt die Anzahl der Male, die der Turbo-Smart mit dem Hauptschalter angeschaltet wurde (Power Cycles), die Gesamtzeit, die der Turbo-Smart mit Strom versorgt wurde (Uptime), die Anzahl der Male, die die Absaugung aktiviert wurde (Work Cycles), die Gesamtbetriebsstunden des Absauggerätes (Work Time), die durchschnittliche Arbeitszeit des Absauggerätes (Aspirator) und die Anzahl der Male, die der Lüfter zur Kühlung der Elektronik aktiviert wurde (Fan Cycles).

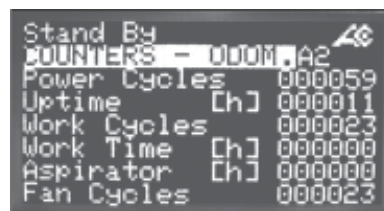

Ereignismenü "A3"

Das Menü zeigt die letzten 10 Ereignisse oder Alarmer, die beim Turbo-Smart aufgetreten sind. Alarmer werden durch eine Zahl angezeigt; lesen Sie in der Tabelle (Seite 94) nach, um sie zu identifizieren.



Control Menu "A2"

COUNTERS - ODOM . A2		
POWER CYCLES	000000	Anzahl der Male, die das Absauggerät mit dem Hauptschalter angeschaltet wurde.
UPTIME [h]	000000	Gesamtzeit, die der Turbo-Smart mit Strom versorgt wurde.
WORK CYCLES	000000	Anzahl der Male, die das Absauggerät durch die Dentaleinheit aktiviert wurde.
WORK TIME [h]	000000	Anzahl der tatsächlichen Betriebsstunden (laufende Motoren).
ASPIRATOR [h]	000000	Durchschnittliche Betriebsstunden des Absaugmotors (UNI-JET 75).
FAN CYCLES	000000	Anzahl der Male, die der Lüfter zur Kühlung der Elektronik aktiviert wurde.

Untermenüs

 drücken, um in die Untermenüs zu gelangen.

Durch Drücken der Scroll Down Taste gelangt man durch die anderen Menüs.

Drive Status

Auf dieses Menü kann ohne Zugangspasswort zugegriffen werden. Das Display zeigt nützliche Informationen über den Turbo-Smart.

User Parameters

Das Passwort 0000123000 benutzen, um in dieses Menü zu gelangen. In diesem Menü können der Unterdruck und die Sprache im Display eingestellt werden sowie der Activation Code eingegeben werden, um Version A zu Version B aufzurüsten.

System Parameters Setup

Das Passwort 0000456000 muss eingegeben werden, um Zugang zu diesem Menü zu erhalten. In diesem Menü können die Ausschaltverzögerungszeit und andere technische Parameter eingestellt werden.

Factory Settings Restricted Access

Auf dieses Menü kann nicht vom Benutzer zugegriffen werden. Nur der Hersteller kann darauf zugreifen.

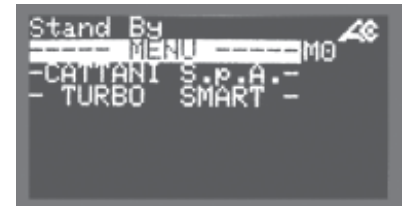



scroll down button
↓

Eingabe von Zugangspasswörtern



Das Drive Status Menu ist das einzige Menü mit Zugang ohne Passwort.

Das Zugangspasswort für das Menü User Parameters ist 0000123000.

Das Zugangspasswort für das Menü System Parameters Setup ist 0000456000.

Im CATTANI S.p.A. Menü  und danach  drücken. Das Display sollte dann Access Password 0000000000 anzeigen.

Die Eingabetaste  drücken, welche einen Cursor bei der letzten Null rechts erscheinen lässt.

 solange drücken, bis der Cursor bei der 6. Null aufleuchtet.  solange drücken, bis die Zahl 1 erscheint.

 drücken, um zu der nächsten Null zu gelangen, dann  solange drücken, bis die Zahl 2 erscheint.

 drücken, um zu der nächsten Null zu gelangen, dann  solange drücken, bis die Zahl 3 erscheint.

Die Eingabetaste  drücken, um das Passwort zu bestätigen. Der Cursor verschwindet.

 drücken, um zum Menü Cattani S.p.A. zurückzukehren.

Es ist nun möglich, die Parameter des Menüs User Parameters abzuändern.

Den Prozess wiederholen und das Passwort 0000456000 eingeben, um Zugang zum Menü System Parameters Setup zu erhalten.

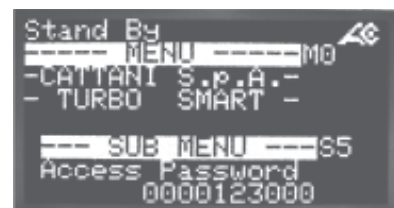
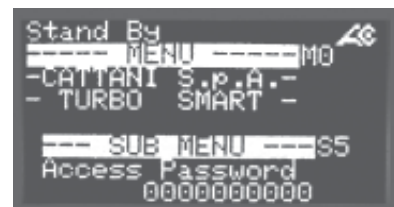
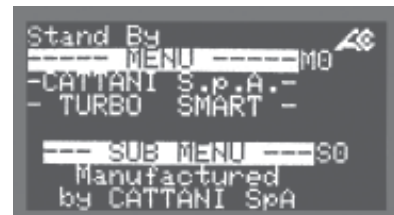
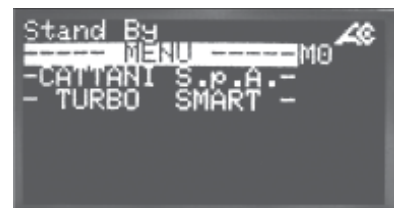
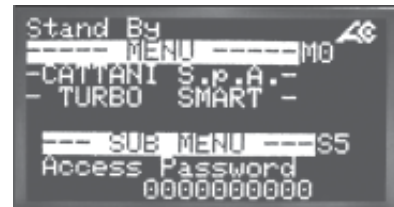

Drive Status

Auf dieses Menü kann ohne Passwort zugegriffen werden. Es zeigt verschiedene technische Parameter bezüglich der Echtzeit-Arbeitungsbedingungen des Turbo-Smarts. Unten aufgelistet sind weitere allgemein benötigte Informationen.

Blower Output Frequency

(Arbeitsfrequenz des Absaugmotors)

(max. Einstellung für Version A: 85 Hz, max. Einstellung für Version B: 110 Hz)

Blower Output Voltage

(Spannung des Absaugmotors)

(max. Einstellung: 220V)

Blower Overall Current

(Ausgangsfrequenz des Absaugmotors)

(max. Einstellung für Version A: 5,5 A, max. Einstellung für Version B: 7,5 A)

Pump (Centrifuge) Output Frequency

(Ausgangsfrequenz des Zentrifugalabscheiders)

(festgelegte Einstellung für Versionen A und B: 55 Hz)

Pump (Centrifuge) Output Voltage

(Spannung des Zentrifugalabscheiders)

(max. Einstellung: 220V)

Pump (Centrifuge) Overall Bus Current

(Vom Zentrifugalabscheider aufgenommenen Strom)

(max. Einstellung für Version A: 5,5 A, max. Einstellung für Version B: 7 A)

scroll down button

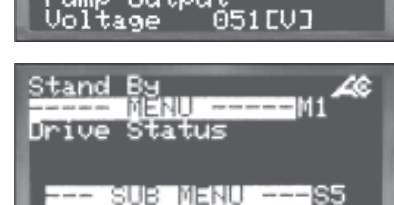
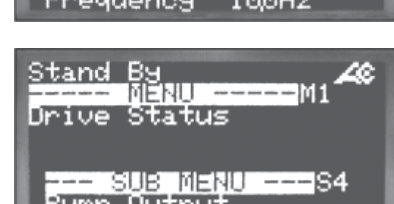
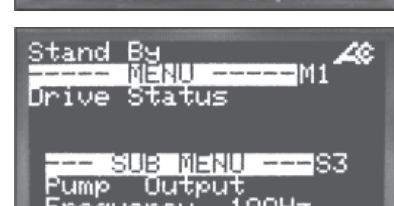
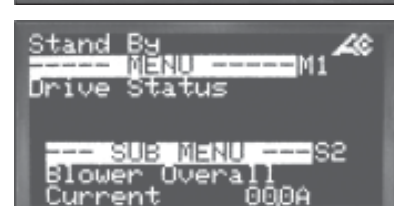
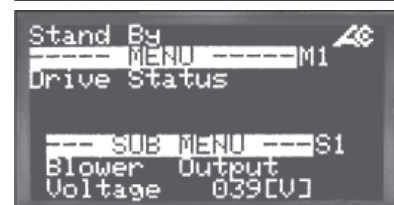
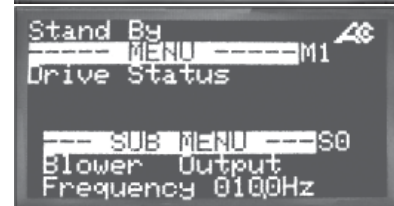

System Temperature

(Temperatur des Systems)

Maximum Detected Temperature

(Max. ermittelte Temperatur)

(+58 °C: Alarm und Stopp des Absauggerätes)

Vacuum

(Unterdruck)

(max. Einstellung: 200 mbar)



Menü User Parameters

Um Zugang zu diesem Menü zu bekommen und/oder Änderungen vorzunehmen, muss man das Zugangspasswort 0000123000 eingeben (siehe Anweisungen auf Seite 84).

Vacuum Set Point (Unterdruck Einstellung)

Dies ist der Wert, bis zu dem die Einheit den Druck beschränkt.

Die Eingabetaste  drücken, um den Cursor erscheinen zu lassen.

Der Wert kann durch den Gebrauch der Pfeiltasten   verändert werden. Die Eingabetaste  erneut drücken, um zu bestätigen und fortzufahren.

Language (Sprache)

Es ist möglich, entweder Englisch (1) oder Italienisch (0) als Sprache im Display zu wählen.

Die Eingabetaste  drücken, um den Cursor zu aktivieren und die Pfeiltasten   benutzen, um 0 oder 1 zu wählen.

Die Eingabetaste  erneut drücken, um die Änderung zu bestätigen und fortzufahren.

scroll down button

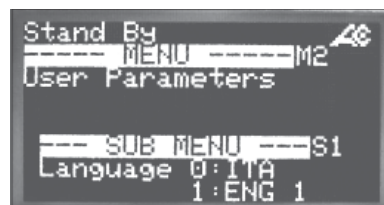
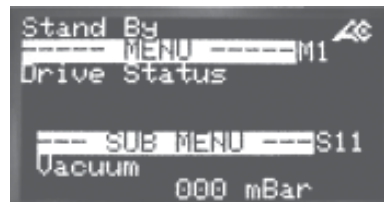
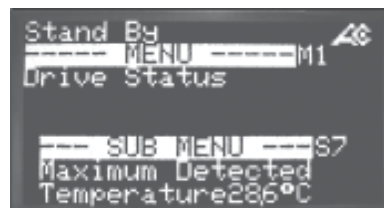
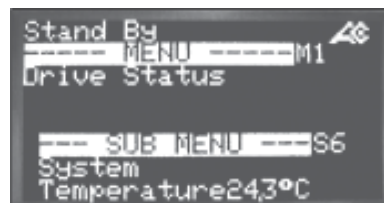

Blower Current Limit

(Max. Stromaufnahme des Saugmotors)

(Max. Einstellung für A: 5,5 A, max. Einstellung für B: 7,5 A)

**Turbo-Smart Off Delay Time**

(Turbo-Smart Abschaltverzögerung)

(Max. Einstellung: 300 sec., min. Einstellung: 10 sec.)

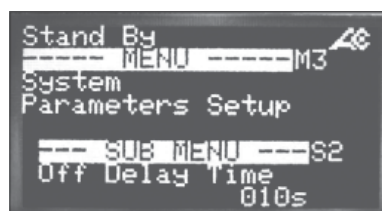
**Pump (Centrifuge) Off Delay Time**

(Abschaltverzögerung des Zentrifugalabscheiders)

(Max. Einstellung: 30 sec., min. Einstellung: 5 sec.)

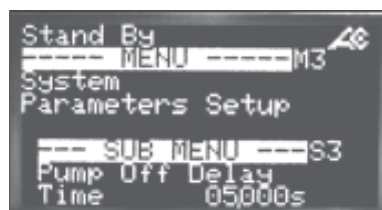
**Control Panel Fan Off Delay Time**

(Abschaltverzögerung des Lüfters zur Kühlung der Elektronik)

(Default Wert Einstellung: 300 sec., max. Einstellung 1.800 sec.)

**Running Options**(Aktivierung oder Deaktivierung des Amalgamstandsensors)
Diese Option aktiviert oder deaktiviert den Amalgamstand-
sensor.

Einstellung auf 0: ohne Amalgam-abscheider

Einstellung auf 1: mit Amalgam-abscheider

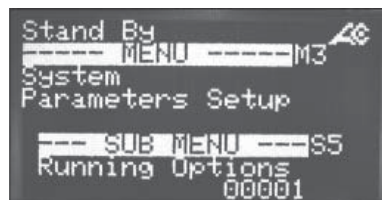
**Drive Commands**

Nur Werksbenutzung.

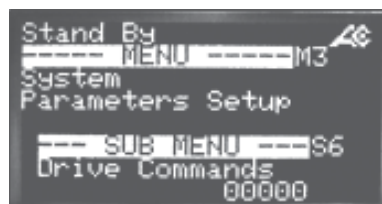

scroll down button



Generated Code (Herstellercode)



Dieser Code wird von der Cattani S.p.A. erzeugt. Jeder Einheit ist ein einziger Code zugeordnet. Dieser Code muss CATTANI mitgeteilt werden, um das Activation Code zu kaufen, um Version A (2 Einheiten) zu Version B (4 Einheiten) aufzurüsten.

Activation Code

Einmal gekauft von Cattani S.p.A. wird dieser Code an dieser Stelle eingegeben, um die Version A (2 Einheiten) zu Version B (4 Einheiten) aufzurüsten.

Die Eingabetaste  drücken, um den Cursor erscheinen zu lassen.

Die Tasten   benutzen, um den Activation Code einzugeben.

Die Tasten   benutzen, um den Wert zu erhöhen oder zu verringern.

Die Eingabetaste  erneut drücken, um zu bestätigen, dann  drücken, um zurück zum Menü User Parameters zu gehen.

Menü System Parameters Setup



Um Zugang zu diesem Menü zu bekommen und/ oder Änderungen vorzunehmen, muss man das Passwort 0000456000 eingeben (siehe Anweisungen auf Seite 84).





Vacuum set point

(Max. Unterdruck Einstellung)

(Max. Einstellung: 200 mbar)

Um Parameter in diesem Menü abzuändern:

Mit   scrollen, um das benötigte Parameter im Display anzuzeigen.

Die Eingabetaste  drücken, um den Cursor zu aktivieren. Der Wert kann durch Benutzen der Pfeiltasten   verändert werden. Sobald der Wert wie gewünscht eingestellt ist, die Eingabetaste  erneut drücken, um zu bestätigen und fortzufahren.

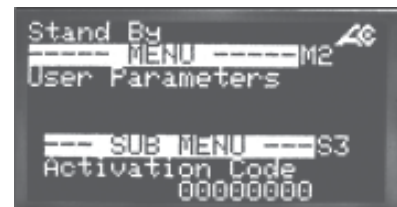
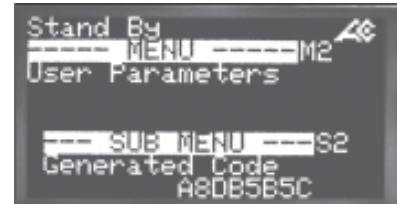

scroll down button 

- *Anweisungen für das Einstellen der zigBee-Kommunikation (drahtlos)*

Stellen Sie die Netzadresse des Geräts ein (min. 100) (max. 110).

Stecken Sie den ZigBee-Key (ETRX2 USB) in die USB-Buchse und starten Sie das Anzeigeprogramm.

Installieren Sie das Programm SMART SYSTEM MONITOR (von Cattani geliefert) auf Ihrem Computer.

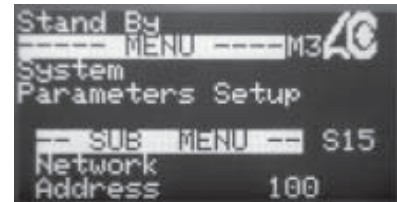

Nachdem das Programm gestartet wurde, erscheint zuerst 10 Sekunden lang das Firmenbild und anschließend das Hauptmenü.



Klicken Sie auf das Menü SERVICE, um die Seite für die Gerätesuche aufzurufen.



Klicken Sie auf die Suche nach verfügbaren Geräten. Das Programm beginnt mit der Suche, was einige Sekunden dauern kann. Anschließend können die verschiedenen verfügbaren Geräte und deren erzeugter Code angezeigt werden. Eventuell muss der Vorgang mehrfach wiederholt werden.

Nachdem das Programm die verfügbaren Geräte gefunden hat, muss in die Homepage zurückgeschaltet werden, um die Parameter anzuzeigen.

Im Fallmenü muss der anzuzeigende Turbo Smart angewählt werden.

An dieser Stelle ist es möglich, die Funktionsparameter anzuzeigen.

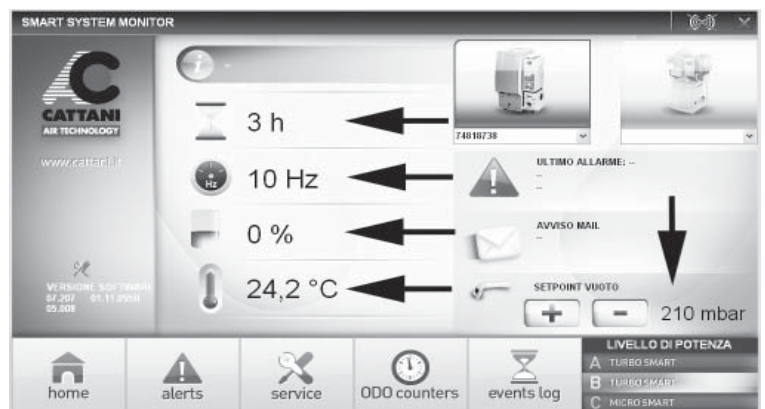
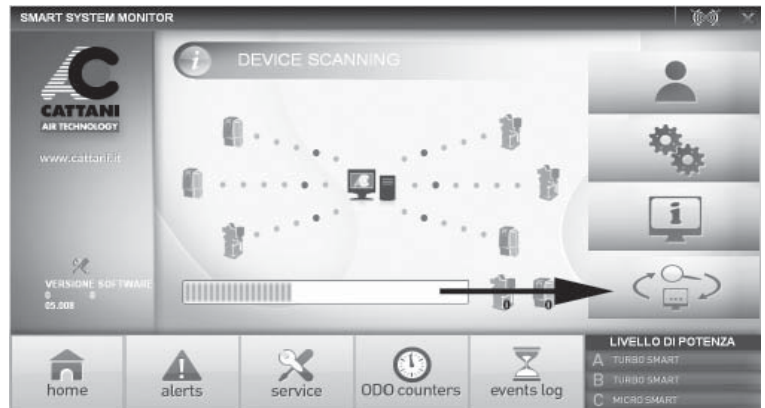

Klicken Sie auf das Icon SERVICE, um Zugriff auf die drei verschiedenen Menüs zu haben, eines ist frei zugänglich und 2 sind passwortgeschützt.

Um das Menü ANWENDERPARAMETER aufzurufen, muss das Passwort 123000 eingegeben und mit OK bestätigt werden.

In diesem Menü können Sie eine andere Sprache auswählen, den gewünschten Druckgrad eingeben und dank eines Aktivierungs-codes das Gerät von einem Absauger für 2 Behandlungsstühle auf einen Absauger für 4 Behandlungsstühle umschalten.

Um das Menü SYSTEMDATEN-EINSTELLUNGEN aufzurufen, muss das Passwort 456000 eingegeben und mit OK bestätigt werden.



In diesem technischen Menü sind alle Parameter des Turbo Smart sichtbar und können verändert werden.

Das Menü INVERTER-ZUSTAND unterliegt keinem Zugangspasswort und ermöglicht das Anzeigen der Funktionsparameter des Geräts bei laufendem Betrieb.

Durch das Anklicken des E-Mail-Icons im Hauptmenü können Daten, wie die Anschrift des Arztes und des Technikers, welche die Störungsnachrichten erhalten sollen, eingegeben werden.

Tritt eine Anomalie auf, so erscheint auf dem Display eine Störungsmeldung und wird eine E-Mail an den zuständigen Techniker gesendet.



Eventuelle im Laufe des Tages aufgetretene Störungen werden im Feld ALERTS mit dem diesbezüglichen Fehlercode angezeigt.

Im Ordner EVENT LOG kann das gesamte Archiv der im Laufe des gesamten Betriebszeitraums am Gerät aufgetretenen Störungen eingesehen werden.

Im Menü ODO COUNTERS werden die Aktivierungszyklen hinterlegt.

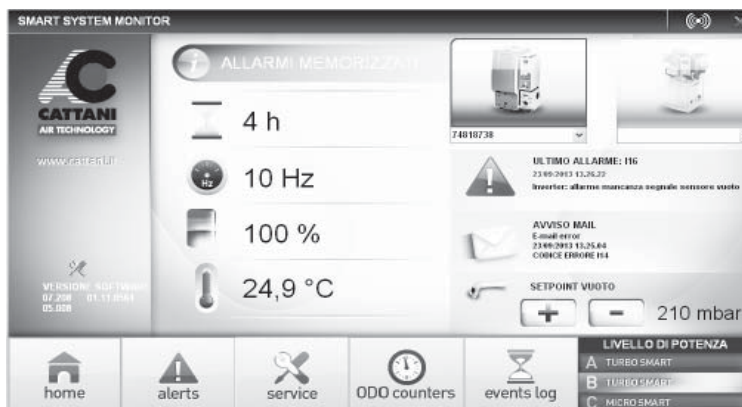
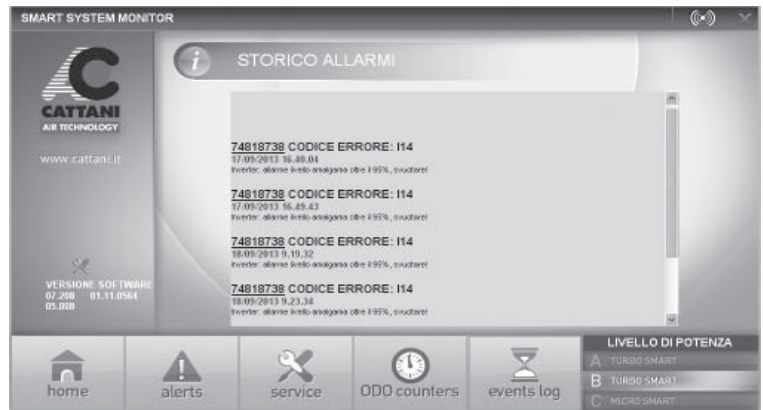

• Alarmbeschreibung

Alarmcode		BESCHREIBUNG	LÖSUNG
AC80 AC80-07			
00	0	Microcontroller-Erinnerungsalarm	Den Techniker kontaktieren
I14	2	Amalgamstand > 95%	Den Amalgamsammelbehälter sobald wie möglich ersetzen
I15	3	Amalgamstand > 100%	Den Amalgamsammelbehälter ersetzen
I00	32	Microcontroller-Erinnerungsalarm	Den Techniker kontaktieren
I01	33	Kurzschluss an einem der beiden Motoren	Prüfen, woher der Kurzschluss kommt, und ihn beseitigen
I02	34	Kurzschluss, bevor die Motoren starten	Den Techniker kontaktieren (die Platine ist wahrscheinlich beschädigt)
I03	35	Die Kondensatoren wurden nicht geladen.	Den Techniker kontaktieren (die Platine ersetzen)
I04	36	Übertemperatur (die Temperatur hat die max. erlaubte Grenze überschritten)	Den Maschinenraum lüften.
I05	37	Überströmung des Gebläses (das Gebläse hat die max. Strömungsgrenze überschritten)	Den Betrieb der Turbine überprüfen (Stillstand oder übermäßige Reibung)
I07	39	Überspannung der Kondensatoren (die Kondensatoren haben die max. Spannungsgrenze überschritten)	Die Netzspannung kontrollieren (max. 260V)
S08	40	Zentrifuge Kurzschluss	Den Kurzschluss beseitigen
S09	41	Platine Kurzschluss am Zentrifugenausgang	Die Platine ersetzen
S10	42	Sofortige Überströmung der Zentrifuge (die Zentrifuge hat die Strömungsgrenze überschritten)	Den Abfluss und den Betrieb der Zentrifuge kontrollieren (Stillstand oder übermäßige Reibung)
S11	43	Zeitverzögerte Überströmung der Zentrifuge (die Zentrifuge hat die Strömungsgrenze überschritten)	Den Abfluss und den Betrieb der Zentrifuge kontrollieren (Stillstand oder übermäßige Reibung)
I13	-	Der Amalgamstandsensor ist nicht verbunden	Der Amalgamstandsensor verbinden
I16	48	Der Vakuumsensorschlauch ist nicht verbunden	Den Vakuumsensorschlauch mit der Zentrifuge verbinden
I17	49	Zentrifugalmotor Temperaturkontakt eingeschaltet	den Raum kühlen/ belüften

- *Wichtige Hinweise*
- *Transport und Lagerung*
- *Transport von Gebrauchtggeräten*

• *Wichtige Hinweise*

- Auf die Geräte wird eine einjährige Garantie gewährt, die ab dem Verkaufsdatum einsetzt. Um Anrecht auf die Garantie zu erhalten, muss dem Hersteller der entsprechende Garantieschein unter Angabe des Kaufdatums, des Verkäufers und des Verwenders zurückgesendet werden.
- Die Garantie und die Haftung des Herstellers verfallen, wenn die Geräte mit ungeeigneten oder von den angegebenen Produkten abweichenden Produkten behandelt werden oder durch Eingriffe jeglicher Art seitens nicht vom Hersteller autorisierter Personen verändert werden.
- Der Hersteller, die Vertragshändler, die Vertreter und autorisierten Techniker stehen gerne für die Lieferung von Ersatzteilen, Unterlagen, Anleitungen und anderen nützlichen Informationen zur Verfügung.
- Der Hersteller behält sich das Recht ohne Vorankündigung auf Abänderungen der von ihm hergestellten Produkte vor, wenn technische Anforderungen, Produktverbesserungen, Zulassungs- und Betriebsschwierigkeiten sowie die Verfügbarkeit von Produkten und Ersatzteilen es erfordern.
- Auf der Internetseite **www.cattani.it** finden Sie unsere **aktualisierten** Handbücher. Wir empfehlen, diese Handbücher und insbesondere die Aktualisierungen betreffend **Sicherheit** zu lesen.
- Der Turbo-Smart ist ein Elektrogerät, daher unterliegt er dem Elektro- und Elektronikgerätegesetz (ElektroG)/ WEEE-Richtlinie.

• *Transport und Lagerung*

- Beim Transport und bei der Lagerung können die verpackten Ausrüstungen Temperaturen zwischen - 10 °C und + 60 °C ausgesetzt werden.
- Die Kolli dürfen keinem Wasser und Wasserstrahl und keiner Feuchtigkeit über 70% ausgesetzt werden.
- Es können jeweils nur drei Kolli mit dem gleichen Gewicht gestapelt werden.

• *Transport von Gebrauchtggeräten*

- Bevor das Geräte verpackt wird, raten wir es mit Fast & Steril 3 (siehe Abschnitt "Signale und Hinweise" und "Ordentliche Wartung") zu reinigen und desinfizieren.
- Alle Schläuche und Öffnungen (einschließlich der, die Flüssigkeit aus dem Inneren der Maschine transportieren) entleeren und mögliche Restflüssigkeiten (einschließlich Desinfektionsmittel) ablaufen lassen, die die Steuertafel beschädigen können. Den Amalgamsammelbehälter entfernen, das Desinfektionsmittel hinzufügen, den Deckel auf dem Behälter platzieren und hermetisch verschließen. Sobald die Saugmaschine trocken ist – jeweils außen und innen – alle Ein- und Auslässe mit den zweckgebundenen Deckeln verschließen, einen neuen (und leeren) Amalgamsammelbehälter in das Gerät einsetzen, sowohl die Saugmaschine als auch die Steuertafel jeweils einzeln in Kunststoffolie einwickeln, um sicherzustellen, dass diese Teile restwassergeschützt sind.
- Das Gerät in einen Polyäthylenbeutel schließen und in einer dreischichtigen Wellpappe verpacken.



TURBO SMART

A UNIVERSAL ASPIRATOR

INDICE

Datos generales de funcionamiento 50/60 Hz	98
Introducción	99
Señales y avisos	99
Montaje y puesta en funcionamiento	100
Mantenimiento ordinario	104
Mantenimiento extraordinario	105
Instrucciones para moverse y modificar algunos parámetros en los menús	106
Instrucciones para configurar la comunicación inalámbrica zigbee (reless)	113
Descripciones de alarmas	118
Avisos importantes	119
Transporte y almacenamiento	119
Transporte de los aparatos usados	119
Ilustración	121

- Datos generales de funcionamiento 50/60 Hz Aspirador para usos dentales Turbo-Smart*

Modelo	Turbo-Smart "A"	Turbo-Smart "B"
Tensión nominal	230 V ~	230 V ~
Frecuencia nominal	50/60 Hz	50/60 Hz
Corriente nominal	7 A	9 A
Modalidad de empleo	Funcionamiento continuo	Funcionamiento continuo
Protección contra la humedad	Común	Común
Potencia máxima absorbida	1,45 kW	1,87 kW
Caudal máximo	86 m ³ /h	105 m ³ /h
Presión máxima de trabajo para el servicio continuo	2000 mm H ₂ O	2000 mm H ₂ O
Velocidad de rotación	70 Hz 85 Hz	70 Hz 110 Hz
Presión sonora versión no carenada * *	68,4 dB(A) 69 dB(A)	68,4 dB(A)73,7 dB(A)
Presión sonora versión carenada de plástico	66,4 dB(A) 67 dB(A)	66,4 dB(A) 72 dB(A)
Presión sonora versión carenada para interior	48,5 dB(A)49,5 dB(A)	48,5 dB(A)52,2 dB(A)
Presión sonora versión carenada para exterior	54 dB(A) 55 dB(A)	54 dB(A) 58,7 dB(A)

~	Corriente alterna	IEC 417-5032
⊕	Toma de tierra (de funcionamiento)	IEC 417-5019
	Grado de de protección contra los contactos directos o indirectos	IEC 60204-1
○	Abierto (desconexión de la red de alimentación)	IEC 417-5008
I	Cerrado (conexión a la red de alimentación)	IEC 417-5007

Nivel de presión sonora detectado según la norma ISO 3746-1979 (E).
 Párametros: r o d = 1,5 - ruido de fondo: 34 dB (A) - instrumento: Brüel & Kjær type 2232.

* * Nivel de presión sonora detectado con velocidad máxima y a la máxima presión.

- *Introducción*
- *Señales y avisos*

- **Introducción**

La siguiente presentación tiene como objetivo de ilustrar el montaje y la puesta en funcionamiento y también informar acerca de los peligros y precauciones útiles para la prevención.

Este manual debe estar siempre disponible para ser consultado durante el desembalaje, el uso, el montaje y la puesta en funcionamiento del Turbo-Smart.

En el sitio de Internet **www.cattani.it** pueden encontrarse nuestros manuales **actualizados**. Recomendamos su consulta especialmente para las actualizaciones sobre la **seguridad**.

- **Señales y avisos**

- *Peligro de sacudidas eléctricas, incluso la de 230 V \sim puede resultar mortal.* 

- *Peligro biológico, infecciones de enfermedades epidémicas.* 

- *Señal genérica de peligro.* 

- *Protecciones personales para trabajos pesados.* 

- *Protecciones personales para peligro biológico.* 

- *Alta temperatura.* 

- *Local aislado de sustancias inflamables, corrosivas o explosivas.* 

- *Dirección obligatoria del flujo o del sentido de rotación.* 

No siempre resulta posible expresar con una señal los avisos de peligro, por ello es necesario que el usuario lea los avisos y los tenga en cuenta convenientemente.

No respetar una señal o un aviso de peligro puede causar daños al operador o al paciente.

No retirar las protecciones para la prevención de accidentes, no modificar las máquinas o su funcionamiento.

A pesar de todo nuestro empeño, es posible que los avisos de peligro no sean exhaustivos; solicitamos la colaboración del usuario, rogándole al mismo tiempo que se encargue él mismo de prever las fuentes de peligro que tal vez no hemos tenido en cuenta y que nos las comunique.

• Montaje y puesta en funcionamiento

• Precauciones recomendadas

Antes de desembalar el aparato, comprobar el exterior del embalaje, poner atención al indicador de daños, si el indicador está rojo, o el cartón dañado, aceptarlo con reserva de controlar el aparato. Desembalar la máquina siguiendo las instrucciones representadas en el mismo embalaje. El cartón es reciclable, si aconseja disponerlo para tal fin respetando las normas vigentes. Conservar las tapas que cierran todas las comunicaciones exterior/interior del equipo, ya que se podrán utilizar para mover el aspirador de sitio.

El montaje de la máquina debe ser efectuado por una persona experta y equipada. El aspirador debe ser colocado en un lugar limpio, lejos de fuentes de calor, de la humedad y del polvo. En las instalaciones externas: balcones, terrazas o jardines, proteger las máquinas de la lluvia, de la suciedad, del hielo y de la exposición directa a los rayos del sol.

Les recomendamos en éstos casos el carenado para exteriores del Turbo-Smart completo de: doble techo aislante, sistema antihielo y sistema de ventilación, suministrado con termostato fijo para la regulación automática de la temperatura. La temperatura ambiente del local técnico no debe ser inferior a los + 5 °C y no debe ser superior a los + 35 °C. Las máquinas carenadas, para interior y exterior, pueden ser pedidas completas de instalación antihielo. Donde fuera necesario ventilar o acondicionar la sala de máquinas, es aconsejable hacer proyectar una instalación de ventilación o de acondicionamiento por parte de un especialista. El local técnico no debe ser accesible para pacientes o personal no autorizado. Cuando no se disponga de dicho local, es necesario que las máquinas estén protegidas por un adecuado carenado, no fácilmente retirable. Utilizar protecciones y carteles indicadores de peligro, a fin de evitar contactos accidentales peligrosos por las sacudidas eléctricas y por la posibilidad (remota pero no excluible) de incendio, de explosión o por el escape de aire y líquidos contaminantes. Utilizar exclusivamente carenados (para exteriores e interiores) estudiados y construidos por el fabricante de las mismas máquinas.

En el local tecnológico no debe haber material inflamable, verificar que no exista la posibilidad de fufas de gas. No conectar a la red eléctrica aparatos dañados, no utilizar cordón de extensión, tomas o enchufes múltiples. Antes de conectar el aparato a la línea de alimentación, verificar que ésta es conforme a las normas CEI 64-8 y que esté presente un interruptor magnetotermico y un interruptor diferencial (clase A o B) (16A) según las normas EN 61008-1. Los pavimentos de color claro, de madera, linóleo, goma o mármol, en contacto con los antivibrantes de goma (1), pueden cambiar de color o quedar marcados por sombras más oscuras. Aislar por tanto los antivibrantes del suelo con un hoja de plástico o de otro producto adecuado para tal fin.

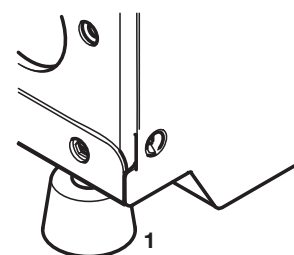
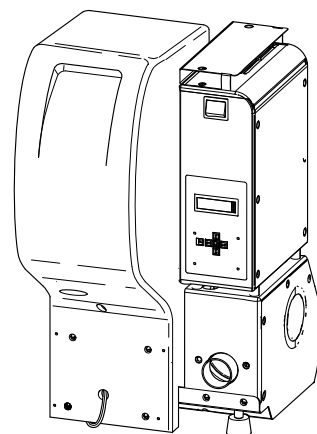
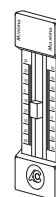
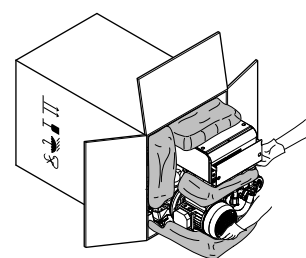

• **Montaje**

Antes de conectar el aspirador a la canalización de la instalación centralizada, asegurarse de que las tuberías aspirantes estén limpias; los residuos pesados podrían dañar el aparato. El tubo de aspiración en PVC (2b) de colore gris claro en dotación con el aparato debe ser conectado al portatubo (2) diámetro 50 mm “entrada liquido aspirado”. Por la parte opuesta el mismo tubo se conectará a la canalización aspirante (3) que llega de las clínicas dentales (pag. 102).

El tubo para el aire expulsado (4b) (d color negro, resistente a la temperatura, con espiral metálica) debe ser conectado al portatubo (4) diámetro 50 mm “salida aire expulsado”, el otro extremo del tubo será conectado al filtro antibacterico (5) pasando preferiblemente a través de un silenciador (5a) siempre en dotación con el aspirador. En la salida del filtro antibacterico, el aire expulsado todavía caliente, deberá ser canalizado al exterior. El portatubo (6), diámetro 18 mm será conectado al tubo de desagüe. Hay que tener presente que, en la versión con hidrociclón, el aspirador drena por caída y que en ningún caso puede descargar hacia arriba. El portatubo (8) diámetro 10 mm “desagüe de emergencia” debe ser conectado al tubo de desagüe.

Los tubos de conexión que unen la máquina a la instalación de aspiración y de desagüe, son flexibles para amortiguar las pequeñas vibraciones derivadas del funcionamiento del aspirador. La canalización aspirante corre generalmente por el suelo, en proximidad del aspirador sube unos 30 cm hasta alcanzar el portatubo (2) (fig. A y B, pag. 121).

También cuando el Turbo-Smart está situado en un piso inferior respecto a los gabinetes, la canalización aspirante debe descender de las clínicas al piso del aspirador, hacer un recorrido de algún metro en el piso sobre el suelo y salir con un tubo flexible hasta el separador centrífugo (fig. B, pag. 121), el fluido aspirado será reabsorbido por el aspirador.

Terminado el montaje se deberá conectar el cable de alimentación a la línea eléctrica del edificio según la normativa EN 61008-1. Por último se conectará la línea de las señales de baja tensión: de los conectores 19 y 20 del circuito AC 80-07 (fig. C “esquema eléctrico AC80-07”, pag. 122) a la línea de los conectores (12) (detalle 12, pag. 102 y Fig. F, pag. 125) que alcanza con conexiones en paralelo todos los equipos de la misma instalación. Asegurarse de que se trata de un contacto limpio (sin tensión).

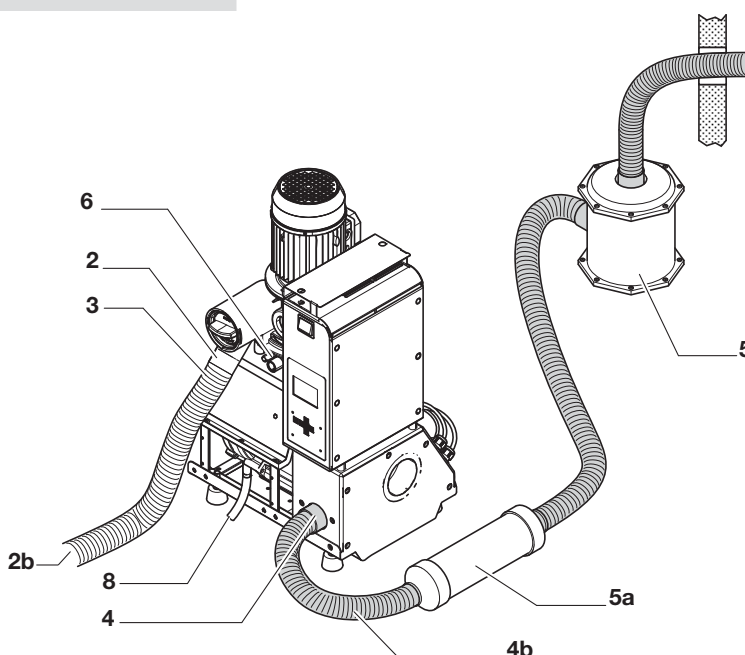
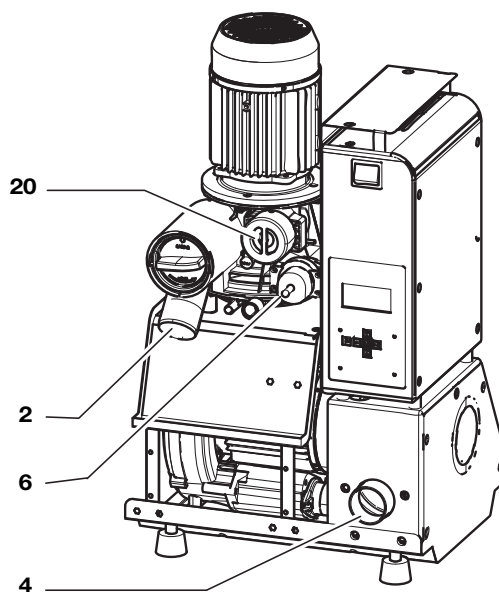

- **Montaje en paralelo**

Es aconsejable montar en paralelo solo máquinas con el mismo caudal y la misma presión de trabajo. Dos o tres aspiradores en paralelo (fig. F) duplican o triplican el caudal, a condición de aumentar diez milímetros el diámetro de la canalización principal por cada aspirador que se añade. Del mismo modo se deberá aumentar el diámetro de la canalización del aire expulsado. El Turbo-Smart se suministra siempre completo de los accesorios necesarios para el montaje en paralelo, no se necesitan por lo tanto válvulas unidireccionales, centrales adicionales o periféricos. Conectados a la misma canalización principal, los dos o tres aspiradores en paralelo, se deberán conectar en paralelo los hilos **(12)** que llegan de los diferentes equipos. Poniendo en paralelo los aspiradores, se deberá poner atención a no invertir los cables de los conectores n° 19 con con los de los conectores n° 20. Con más aspiradores en paralelo, es posible que un aparato se pare sin que los trabajadores se den cuenta. Para evitar tal inconveniente, los conectores 8 y 9 de la central (contacto limpio) permiten llevar una señal de alarma a distancia. Los Turbo-Smart en paralelo funcionan mejor y ofrecen un mayor ahorro energético, cuando se activan al mismo tiempo, independientemente de la necesidad. Quitar corriente a uno de los aspiradores, no conlleva un ahorro energético y disminuye el rendimiento de los aspiradores que quedan en servicio.

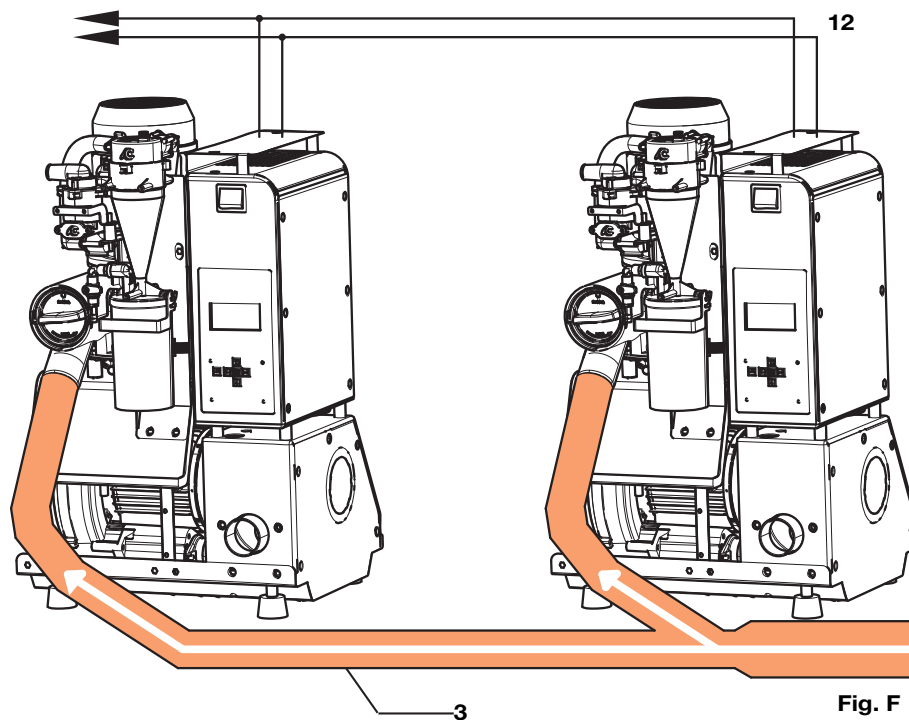

Fig. F

Draw. F

Puesta en funcionamiento, comprobación e instrucción del personal.

Una vez montado y conectado el aspirador, bastará apretar el botón encendido/apagado y hacer partir la señal de uno de los equipos conectados, para que se produzca el arranque del aspirador. Para verificar el correcto funcionamiento del aspirador Turbo-Smart, es aconsejable efectuar los test de tipo dinámico (ver fig. D, pag. 123) y el diagrama de trabajo del Turbo-Smart, fig. E pag. 124). Las instrucciones del personal para el uso y el mantenimiento ordinarios del aspirador, se hace con el aparato nuevo aún no contaminado. El personal de la clínica debe ser instruido para seguir en el display las fases de funcionamiento del Turbo-Smart, a interpretar avisos de peligro y hacer una correcta manutención con Puli-Jet plus new con antical **(A)**, Pulse Cleaner **(B)** y pastillas antiespumogénas desinfectantes **(C)**.

Funcionamiento

El grupo aspirante **(9)** (a través del tubo **10**) crea la depresión en el separador centrífugo **(11)**. El fluido proveniente de los equipos, a través del tubo colector **(2)** entra en el separador centrífugo **(11)**.

El separador centrífugo separa el aire de los líquidos: el aire es expulsado al exterior a través del tubo **(4)** mientras los líquidos (en ausencia del separador de amalgama) son enviados al desagüe a través del tubo de descarga conectado al portatubo **(6)**.

La puesta en marcha del separador centrífugo **(11)** es anticipada con respecto a la turbina **(9)**, por lo tanto permite expulsar líquidos acumulados eventualmente en el separador centrífugo, antes de que haya arrancado el aspirador. Además, cuando se apaga la máquina, un temporizador regulable mantendrá funcionando el aspirador de 10 a 120 segundos.

El separador de amalgama ISO 18

El Turbo-Smart puede ser pedido con separador de amalgama "Hidrociclón ISO 18" (el separador de amalgama va siempre acompañado del manual de instrucciones y manutención).

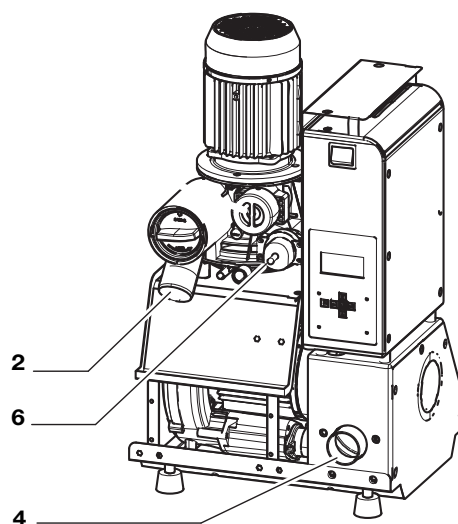
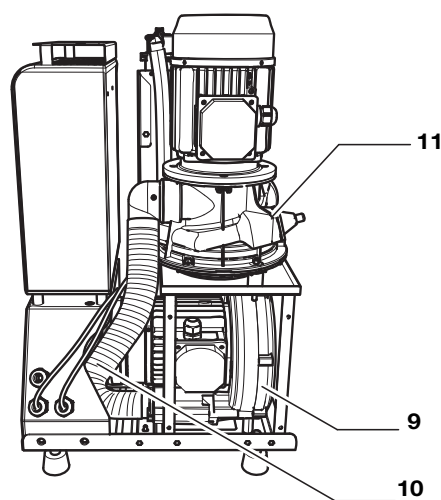
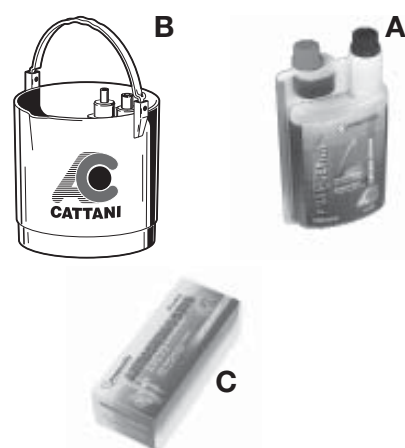

• *Mantenimiento ordinario*

El mantenimiento ordinario debe ser efectuado por el personal de la clínica expresamente instruido.

- Se recuerda poner particular atención a todas las señales de peligro y de protegerse con gafas, guantes y mascarillas monouso;

Cada día

- Controllare sul display le eventuali segnalazioni di allarmi, in presenza di avvisi di pericolo mettersi in contatto con il tecnico.

Cada tarde

- aspiración vespertina de la solución de Puli-Jet plus new con antical desinfectante **(A)** con Pulse Cleaner **(B)**;
- antes de llevar a cabo cualquier intervención en la máquina, quitar la corriente.

Cada día

- colocar las pastillas de antiespumógeno en los filtros del sillón equipado.

Periódicamente

- Tener limpio el filtro del aspirador.

Ocasionalmente

- controlar que no se formen obstáculos para la libre ventilación del aspirador;
- mantener libre el local tecnológico de todo aquello que no atañe a las mismas máquinas, con especial referencia a material inflamable. Vigilar que no se dé la posibilidad de formación de mezclas corrosivas, inflamables y explosivas.



ALLARME:
TEMPERATURA ELEVATA

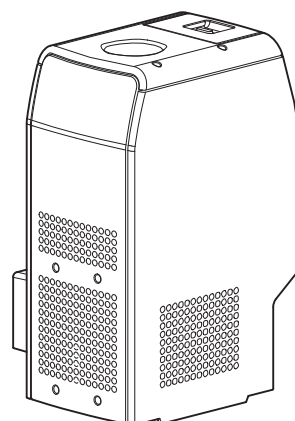
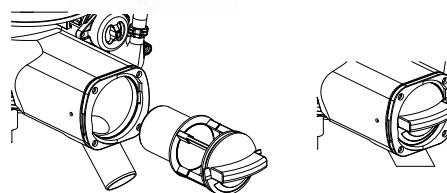
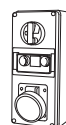
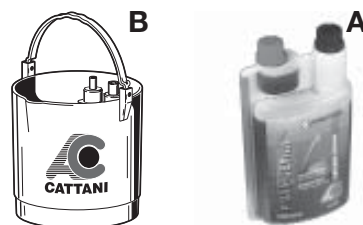

• *Mantenimiento extraordinario*

El mantenimiento extraordinario debe ser confiado a un técnico preparado dotado de repuestos originales:

- poner particular atención a todas las señales de peligro y protegerse con gafas, guantes y mascarillas monouso;
- controlar el estado de mantenimiento ordinario; verificar que se usen productos Magnolia;
- antes de intervenir sobre los aparatos, hacer algunos lavados con Fast & Steril 3 (D), esperar 15 min. hasta que la acción desinfectante haya hecho su efecto.

Controles aconsejados cada 12 meses

- controlar las temperaturas máximas registradas y todas las señales de alarma, intervenir en consecuencia;
- controlar el ruido del aspirador: máx. 72 dB declarados según la norma 3047 (E);
- si es necesario con un chorro de aire seco que no supere la tensión de 2 bar, eliminar el polvo de los componentes electrónicos del interior del circuito AC80 y con un chorro de aire seco de 6 bar limpiar los orificios de la tapa delantera del motor de aspiración (15);
- controlar las condiciones de los tubos de plástico, en particular de los tubos bajo presión de conexión entre el separador centrífugo (11) y el Hidrociclón ISO. Aconsejamos sustituir estos tubos cada 12-18 meses.

Controles aconsejados cada 18-24 meses

- controlar las condiciones de funcionamiento del separador centrífugo (11) y de la válvula de recirculación (14).

Controles aconsejados cada 10.000 horas

- cada vez que se desmonta un componente que contiene una parte de goma (O-Ring, junta o retén) sustituir la parte de goma;
- sustituir los cojinetes de los motores;
- constatando precariedad de mantenimiento ordinario o en el caso de que sean usados productos impropios, instruir al personal e informar al responsable de la clínica.

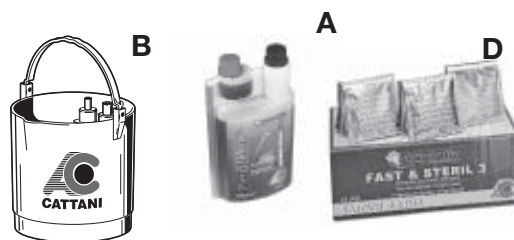

ALLARME:
TEMPERATURA ELEVATA

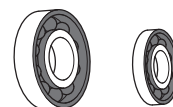
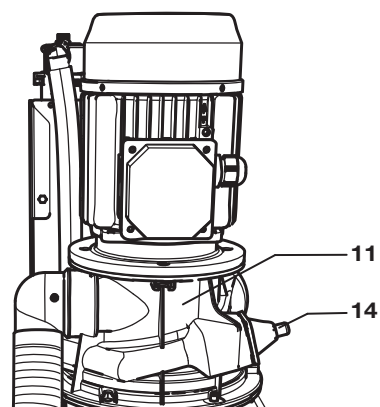
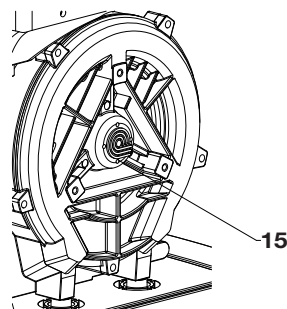

- *Instrucciones para moverse y modificar algunos parámetros en los menús*

Menús principales

Al encender el Turbo-Smart, el display gráfico muestra por 10 segundos el logo de Cattani S.p.A., al final del cual aparecerá el menú principal.



Menú principal "A1"

Son visibles algunos parámetros como la frecuencia, el tiempo de activación del aspirador, la temperatura, el contenedor de amalgama (si lo lleva) y la revisión del software del sistema.



Menú de control "A2"

Son visibles el número de veces que el Turbo-Smart ha sido encendido (Power Cycles), las horas de trabajo totales (Uptime), el número de veces de activación del aspirador (Work Cycles), las horas efectivas de uso del aspirador (Work Time), la media de las horas de trabajo del motor de aspiración (Aspirator) y el número de activaciones del ventilador (Fan Cycles).

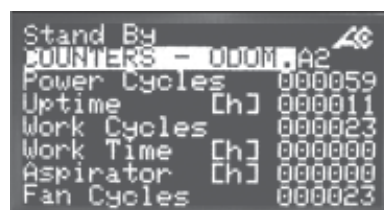

Menú de alarmas "A3"

Son visibles las últimas 10 indicaciones o alarmas ocurridas en el Turbo Smart. Las alarmas vienen indicadas con un número, para la codificación consultar la tabla a la página 118.



Menú de control "A2"

COUNTERS - ODOM . A2		
POWER CYCLES	000000	Número de encendidos del interruptor general
UPTIME [h]	000000	Horas totales de encendido
WORK CYCLES	000000	Número de activaciones del comando de aspiración
WORK TIME [h]	000000	Horas de trabajo efectivo (motores en funcionamiento)
ASPIRATOR [h]	000000	Horas medias de trabajo del motor de aspiración (UNI-JET 75)
FAN CYCLES	000000	Número de activaciones de la véntola de ventilación de la central

Menús secundarios

Pulsando  se accede a los menús secundarios.

Desde este menú se accede a los siguientes pulsando la flecha .

Drive Status

A este menú se accede sin necesidad de "Password", se pueden visualizar aquí informaciones útiles sobre el funcionamiento del Turbo-Smart.

User Parameters

Se accede introduciendo la password "0000123000".

Permite modificar el nivel de vacío, el idioma e insertar el "Código de Activación" para pasar de versión "A" a "B".

System Parameters Setup

Se accede introduciendo la password "0000456000".

Permite modificar el retardo de parada y otros parámetros de tipo técnico.

Factory Settings Restricted Access

Menú no accesible al público, es para uso exclusivo de la fábrica Cattani.

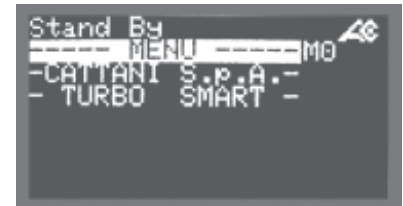



scroll down button
↓

Como entrar e introducir la "Password"

Drive Status es sólo un menú de consulta sin uso de ninguna "Password".

La "Password" de acceso al menú "User Parameters" es "0000123000".



La "Password" de acceso al menú "System Parameters Setup" es "0000456000".



Del menú "CATTANI S.p.A.", pulsar la flecha  después la flecha  y en el display aparecerá el menú "Access Password" 0000000000.

Ahora pulsando el botón , aparecerá el cursor sobre el 0 a la derecha.

Pulsando  llevar el cursor sobre el sexto 0.

Pulsando  aparecerá 1.

Pulsar  ir al 0 de al lado y con  escribir 2.

Premere  ir al 0 de al lado y con  escribir 3.

Pulsar el botón Enter  para confirmar la "Password" y el cursor desaparecerá.

Pulsar  para volver al menú "Cattani S.p.A."

Ahora será posible modificar los parámetros del menú "User Parameters".

Repetir el mismo procedimiento introduciendo la password 0000456000 para acceder a las modificaciones del menú "System Parameters Setup".

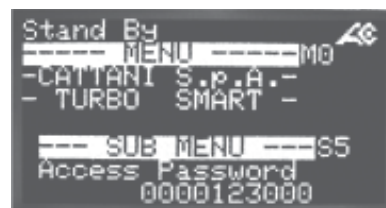
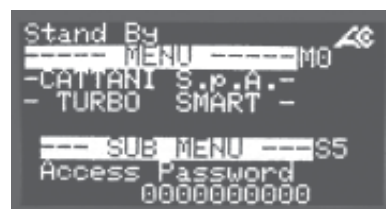
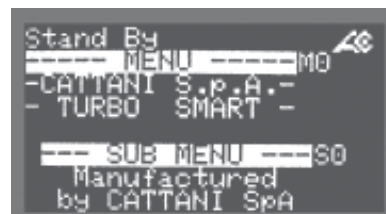
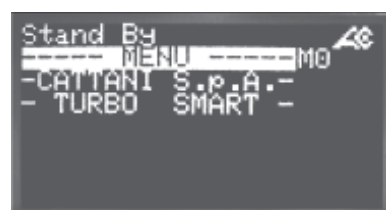
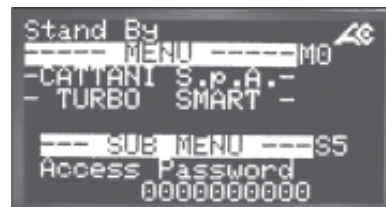

Menu "Drive Status"

Este menú es visible sin la introducción de ninguna "password", y tiene como finalidad hacer visibles algunos parámetros del estado de funcionamiento del Turbo-Smart. A continuación se indican algunos de éstos parámetros.

Blower Output Frequency

(Frecuencia Motor Aspiración)

(Máx. 85 Hz versión A, Máx 110 Hz versión B)

Blower Output Voltage

(Tensión Salida Motor Aspiración)

(Máx. 220 V)

Blower Overall Current

(Corriente Motor Aspiración)

(Máx. 5,5 A versión A, Máx 7,5 A versión B)

Pump (Centrifuge) Output Frequency

(Frecuencia Separador Centrífugo)

(55 Hz no variables ya sea para versión A ó B)

Pump (Centrifuge) Output Voltage

(Tensión Salida Separador Centrífugo)

(Máx. 220V)

Pump (Centrifuge) Overall Bus Current

(Corriente Separador Centrífugo)

(Máx. 5,5 A versión A, Máx. 7 A versión B)

scroll down button

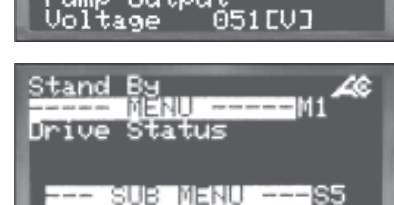
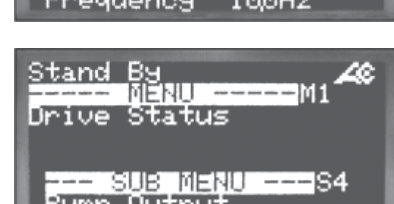
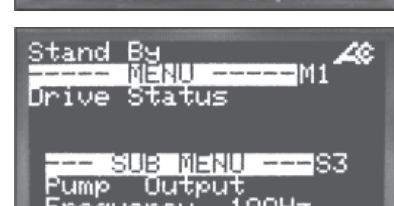
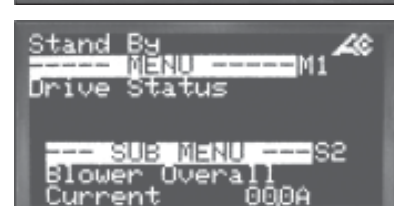
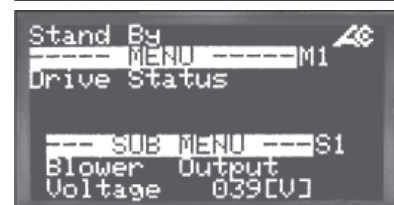
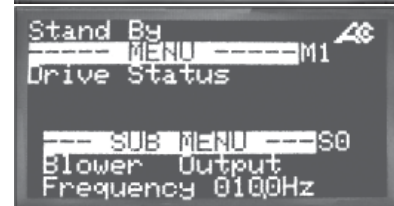

System Temperature
(Temperatura del Sistema)

Maximum Detected Temperature
(Máxima Temperatura Registrada)
(58 °C Alarma y Bloqueo motor Aspiración)

Vacuum
(Nivel de Vacío Instantáneo)
(Máx. 200 mbar)





Menu "User Parameters"

A este menú se accede introduciendo la "Password de Acceso" 0000123000 (ver instrucciones en la pag. 108).

Será ahora posible realizar algunas modificaciones.



Vacuum Set Point (Nivel de Vacío)

Muestra el nivel de vacío seleccionado.

Pulsar  Enter para modificar, con las flechas   introducir el valor deseado. Pulsar  Enter para confirmar la modificación y continuar.

Language (Idioma)

Es posible la selección entre idioma Inglés (1) e Italiano (0).

Pulsar  Enter y modificar y con las flechas   seleccionar 0 o 1.

Pulsar  Enter para confirmar la modificación y continuar.

scroll down button

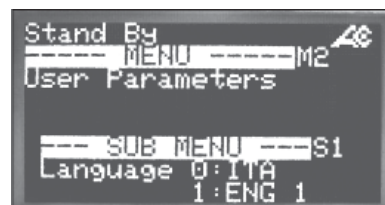
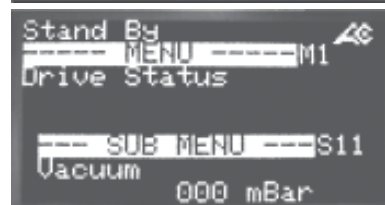
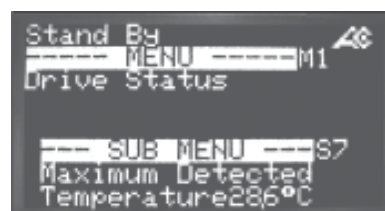
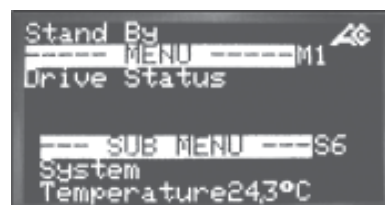

Generated Code (Código Generado)

Este código es generado por Cattani S.p.A. Cada aparato tiene un código único específico. Este código deberá ser comunicado a Cattani S.p.A. para adquirir el “Código de activación” para transformar el Turbo-Smart de versión A (2 sillones), a versión B (4 sillones).

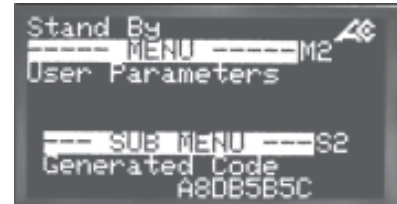

Activation Code (Código de Activación)

Este es el código que, adquirido de Cattani S.p.A., podrá ser introducido para transformar el Turbo-Smart de A (2 sillones) a B (4 sillones).

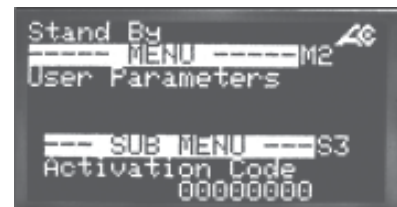

Pulsar Enter para activar el cursor.

Usando las flechas moverse para introducir el Código de Activación, y con las flechas incrementar o disminuir el valor.

Pulsar Enter al final para confirmar y entonces pulsar para volver al menú User Parameters o Parámetros de Usuario.

Menu “System Parameters Setup”

A este menú se accede introduciendo la “Password de Acceso” 0000456000 (ver instrucciones en la pag. 108).

Será ahora posible realizar algunas modificaciones.



Vacuum Set Point

(Nivel de Vacío)

(Máx 200 mbar)



Para cambiar los parámetros en este menú:

Mover las páginas de los menús con las flechas para buscar el o los parámetros a modificar.

Pulsar Enter para activar el cursor, con las flechas introducir el valor deseado. Pulsar Enter para confirmar la modificación y continuar.

scroll down button

Blower Current Limit

(Corriente Máxima Motor Aspiración)

(Máx. 5,5 A versión A)

(Máx. 7,5 A versión B)

Off Delay Time

(Retardo parada del Turbo-Smart)

(Máx. 300", Min. 10")

Pump Off Delay Time

(Retardo Apagado Separador Centrifugo)

(Máx. 30", Min. 5")

Fan Off Delay Time

(Retardo Apagado Véntola Central)

(Defecto 300", Máx. 1800")

Running Options

(Opciones utilizadas)

Habilita o deshabilita la lectura del sensor de amalgama.

0- sin separador de amalgama

1- con separador de amalgama

Drive Commands

(Comandos del Inverter)

Reservado a regulaciones en fábrica.

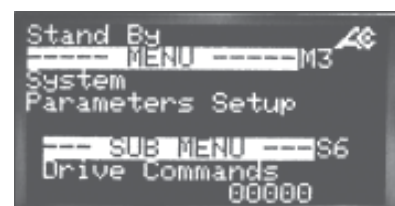
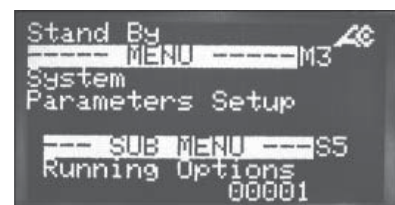
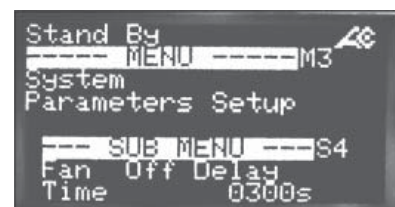
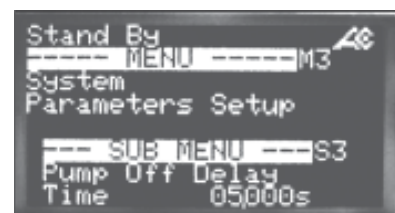
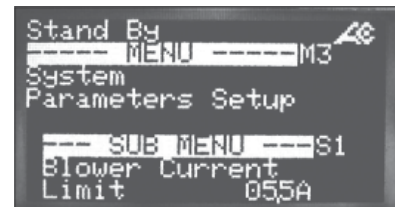

scroll down button

- *Instrucciones para configurar la comunicación inalámbrica zigbee (reless)*

Configurar la dirección de red de la máquina (mín. 100) (máx. 110)

Insertar la clave de comunicación Zig-bee (ETRX2 USB) en el puerto USB del ordenador y lanzar el programa de visualización.

Instalar el programa SMART SYSTEM MONITOR (proporcionado por la empresa Cattani) en el ordenador.

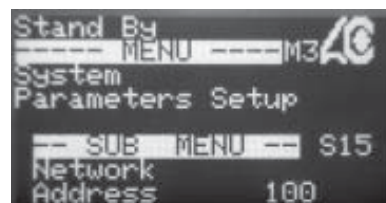

Una vez lanzado el programa, aparecerá durante 10 segundos la imagen corporativa, y después se entrará en el menú principal.



Hacer clic en el menú SERVICE para poder entrar en la página de búsqueda de los dispositivos.



ESPAÑOL

Hacer clic en la búsqueda de los dispositivos disponibles; el programa comenzará la búsqueda, la operación puede requerir varios segundos.

Al final se podrán visualizar las distintas máquinas disponibles y el relativo código que se ha generado; podría ser necesario repetir la operación varias veces.

Una vez que el programa haya encontrado los dispositivos disponibles, será necesario volver a la página de inicio para poder visualizar los parámetros.

Mediante el menú desplegable hay que elegir qué Turbo Smart se desea visualizar.

Llegados a este punto, será posible visualizar los parámetros funcionales.

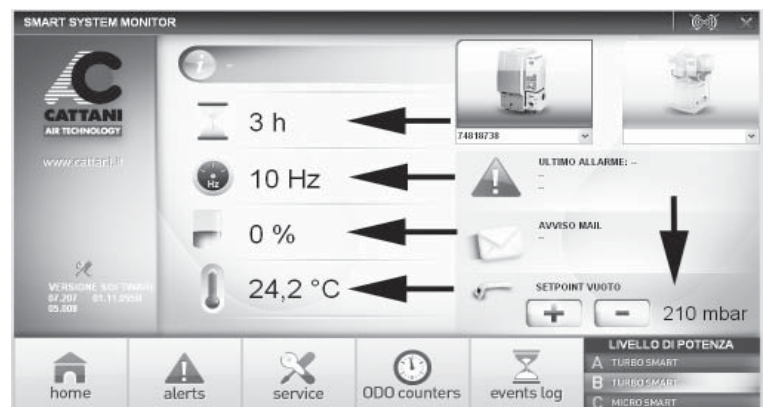
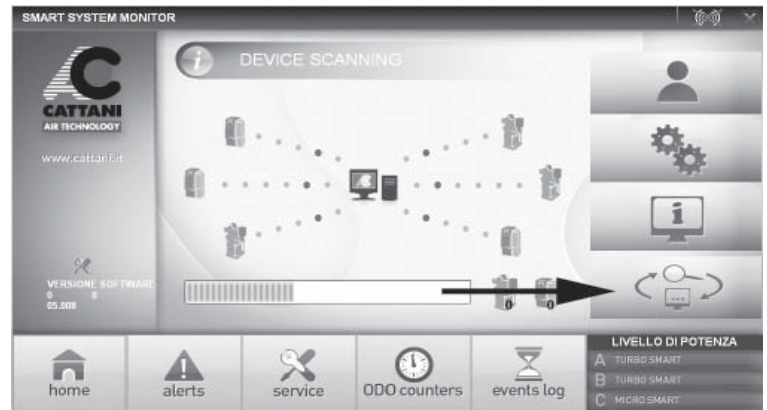

Haciendo clic en el icono SERVICE se podrá acceder a tres menús diferentes, uno libre y 2 protegidos por contraseña.

Para entrar en el menú PARÁMETROS USUARIO es preciso teclear la contraseña 123000 y pulsar OK.

En este menú es posible cambiar el idioma, plantear el nivel de presión deseado y transformar la máquina de aspirador para 2 sillones a aspirador para 4 sillones gracias a un código de activación.

Para entrar en el menú PLANTEAMIENTOS DATOS DE SISTEMA es preciso teclear la contraseña 456000 y pulsar OK.



ESPAÑOL

En este menú técnico resultan visibles y modificables todos los parámetros del Turbo Smart.



El menú ESTADO INVERTER no necesita ninguna contraseña de acceso y permite visualizar los parámetros funcionales de la máquina mientras está funcionando.



Desde el menú principal, haciendo clic en el icono de correo electrónico se podrán insertar los datos, como la dirección del médico y del técnico que tendrá que recibir las comunicaciones de alarma.



En caso de anomalía, se visualiza una alarma en la pantalla y además se envía un mail al técnico de referencia.



Las eventuales alarmas acaecidas durante la jornada se visualizan con un código de error y su descripción dentro de la casilla ALERTAS.

En la carpeta EVENT LOG se podrá visualizar todo el archivo histórico de las alarmas que se han presentado en la máquina durante todo el periodo de funcionamiento.

En el menú ODO COUNTERS se memorizan los ciclos de activación.

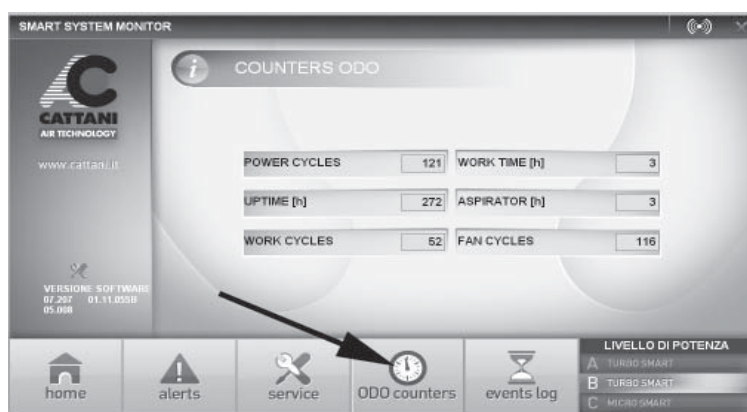
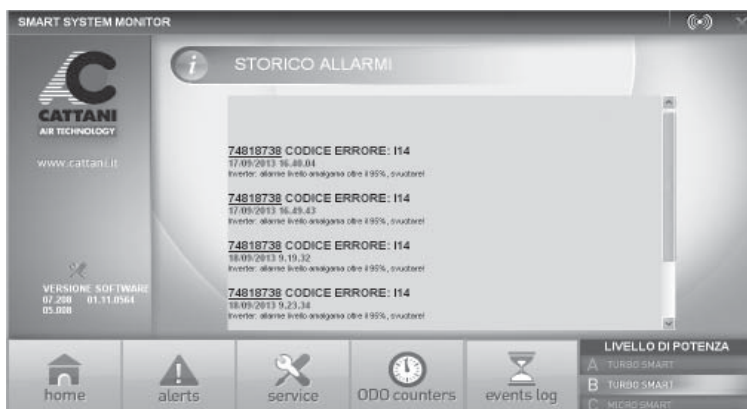

ESPAÑOL

• *Descripciones de alarmas*

Código alarma		DESCRIPCION	REMEDIO
AC80 AC80-07			
00	0	Alarma memoria microcontrolador	Contactar con el técnico
I14	2	Superado el 95% nivel amalgama	Sustituir el contenedor de amalgama en cuanto sea posible
I15	3	Superado el 100% nivel amalgama	Sustituir los contenedores de amalgama
I00	32	Alarma memoria microcontrolador	Contactar con el técnico
I01	33	Cortocircuito debido a uno de los dos motores	Verificar de dónde proviene el cortocircuito y eliminarlo
I02	34	Cortocircuito antes del comando de los motores	Contactar con el técnico (probable circuito dañado)
I03	35	Falta carga condensadore	Contactar al técnico (sustituir el circuito)
I04	36	Superado límite de temperatura	Airear la sala de máquinas
I05	37	Superado el límite de corriente del aspirador	Verificar el funcionamiento del aspirador (bloqueo o resistencia excesiva)
I07	39	Superada la tensión máxima en los condensadores	Verificar la tensión de red, máx. 260V
S08	40	Cortocircuito centrifuga	Quitar el cortocircuito
S09	41	Cortocircuito del circuito en la salida de la centrifuga	Sustituir el circuito
S10	42	Superado el límite de corriente instantánea de la centrifuga	Eliminar los sifones de la tubería, o verificar el funcionamiento de la centrifuga (bloqueo o resistencia excesiva)
S11	43	Superado el límite de corriente de retardo de la centrifuga	Eliminar los sifones de la tubería, o verificar el funcionamiento de la centrifuga (bloqueo o resistencia excesiva)
I13	-	Sensor de nivel amalgama desconectado	Conectar el sensor de nivel amalgama
I16	48	Tubo sensor de vacío desconectado	Conectar el tubo sensor de vacío con la centrifuga
I17	49	Apertura pastilla térmica centrifuga	Airear el ambiente

- *Avisos importantes*
- *Transporte y almacenamiento*
- *Transporte de los aparatos usados*

• *Avisos importantes*

- Los aparatos tienen una garantía de un año a partir de la fecha de venta, con la condición de que se envíe a la empresa fabricante el talón de garantía con la indicación de la fecha de venta, el vendedor y el cliente usuario.
- La garantía y la responsabilidad del fabricante caducan cuando los aparatos son tratados con productos no aptos o distintos de los indicados por el fabricante, utilizados de manera incorrecta, o cuando personas no autorizadas por el fabricante los manipulan.
- La empresa fabricante, los concesionarios, los agentes y los técnicos autorizados están a su disposición para darles sugerencias, indicaciones y para suministrarles documentación, piezas de recambio y todo lo que pueda serles útil.
- Por exigencias técnicas, mejoramiento de los productos, problemas normativos y funcionales, dificultades de encontrar algunos productos y semimanufacturados, la empresa fabricante se reserva el derecho de aportar modificaciones a la producción sin previo aviso.
- En la página web: **www.cattani.it** se puede encontrar los manuales **actualizados**. Se aconseja su consulta especialmente para las actualizaciones de **seguridad**.
- Turbo-Smart es un aparato EEE, por lo que se somete a la legislación RAEE (Residuos de Aparatos Eléctricos y Electrónicos).

• *Transporte y almacenamiento*

- Durante el transporte y almacenamiento, los equipamientos embalados podrán ser expuestos a temperaturas comprendidas entre - 10 °C y + 60 °C.
- Los bultos no podrán ser expuestos al agua y salpicaduras y no podrán soportar una humedad superior al 70%.
- Los bultos se pueden superponer sólo en tercera fila si son del mismo peso.

• *Transporte de los aparatos usados*

- Antes de embalar, recomendamos deterger y desinfectar el aspirador con Fast & Steril 3 (véanse los capítulos “Señales y avisos” y “Mantenimiento ordinario”).
- Vaciar todas las tuberías y las comunicaciones exterior/interior. Posibles residuos de líquido (incluido de desinfectante) podrían dañar la centralita. Remover el vaso de recogida de amalgama, añadir el desinfectante y cerrar el vaso con la tapa hermética. Con aspirador seco tanto exteriormente como interiormente, cerrar todas las comunicaciones exterior/interior con la tapa adecuada y montar el vaso de recogida de amalgama nuevo. Procurar embalar separadamente el equipo y la centralita, al fin de maximizar la impermeabilización.
- Cerrar el aparato en saco de polietileno y embalar en cartón ondulado a tres capas.

- SCHEMA DI MONTAGGIO TURBO-SMART
- INSTALLATION LAYOUT

MONTAGGIO AL PIANO

INSTALLATION ON THE SAME FLOOR OF THE DENTAL UNITS

Fig. A
Draw. A

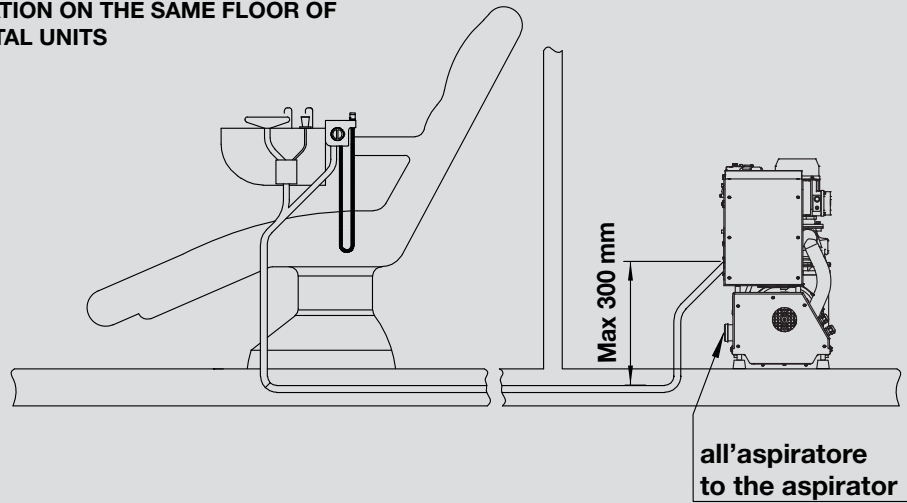

MONTAGGIO SOTTOSTANTE

INSTALLATION ON A LOWER FLOOR THAN THE ONE OF THE DENTAL UNITS

Fig. B
Draw. B

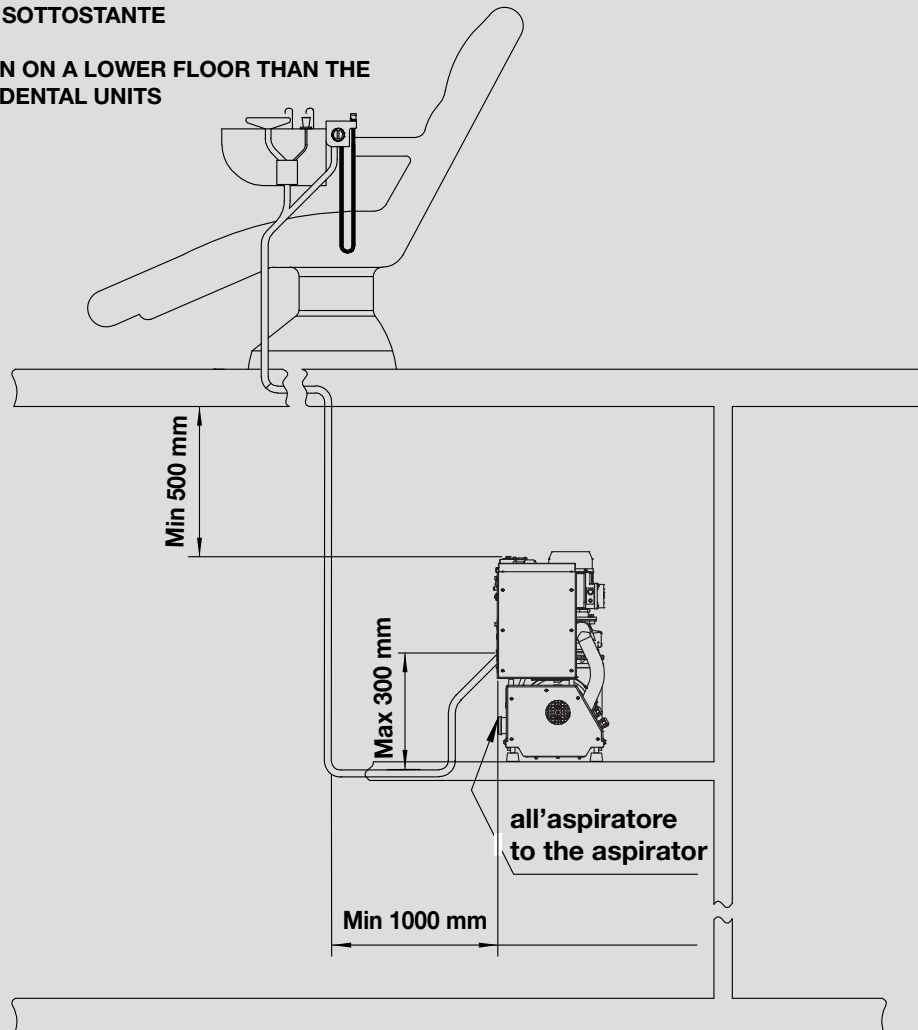

- COLLEGAMENTI CIRCUITO INVERTER AC80-07
- INVERTER AC80-07 CONNECTIONS

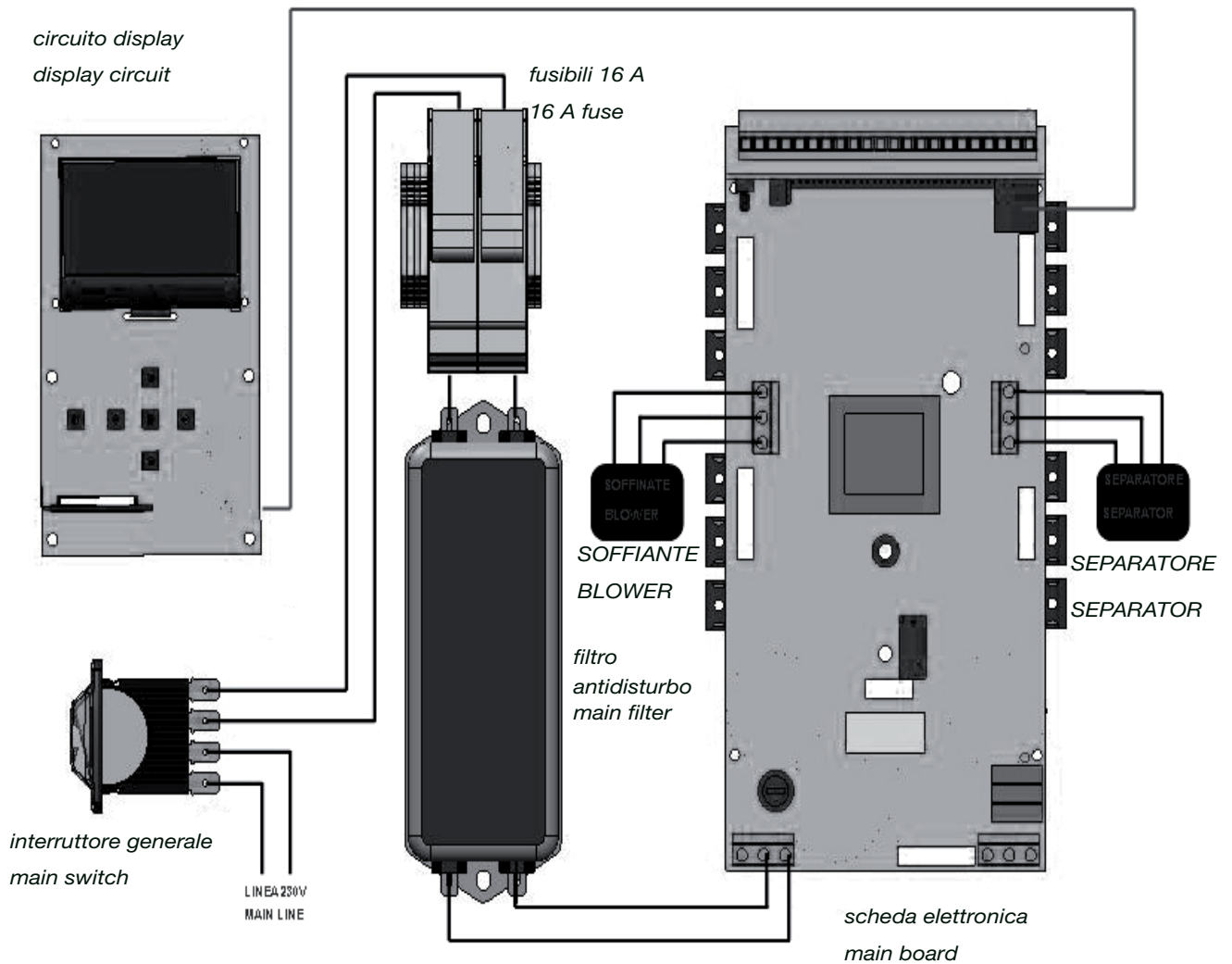

Fig. C

Draw. C

- *PROVE DI DIAGNOSI SUI TURBO-SMART*
- *DIAGNOSTIC TESTS ON TURBO-SMART*

Per verificare il corretto funzionamento del Turbo-Smart, si possono effettuare alcuni test di tipo dinamico, di seguito esposti.

Si dovrà eseguire il test a macchina in funzione e con l'ingresso d'aspirazione libero, non collegato alla tubazione. L'altro test dovrà essere eseguito con l'ingresso d'aspirazione chiuso.

Here below you can find the description of some dynamic tests useful to check the correct working of Turbo-Smart.

One test must be carried out on running machines with open aspiration inlet not connected to the piping, the other one with closed aspiration inlet.

Modello Turbo-Smart Turbo-Smart model	Frequenza raggiunta Reached frequency [Hz]	Prevalenza raggiunta Reached head [mbar]	I totale Total I [A]	I separatore centrifugo Centrifugal separator I [A]	Condizione Aspiration inlet
Versione A Version A	85	40 ÷ 50	3 ÷ 4,5	0,2 ÷ 0,5	Ingresso aspirazione aperto in aria Open
Versione B Version B	110	60 ÷ 70	6 ÷ 7,5	0,2 ÷ 0,5	Ingresso aspirazione aperto in aria Open
Versione A/B Version A/B	60 ÷ 70	195 ÷ 200	4 ÷ 5	0,2 ÷ 0,5	Ingresso aspirazione chiuso Closed

Fig. D

Draw. D

- **DIAGRAMMA DI LAVORO DI TURBO-SMART**
- **TURBO SMART WORKING DIAGRAM**

ASPIRAZIONE mbar
ASPIRATION mbar

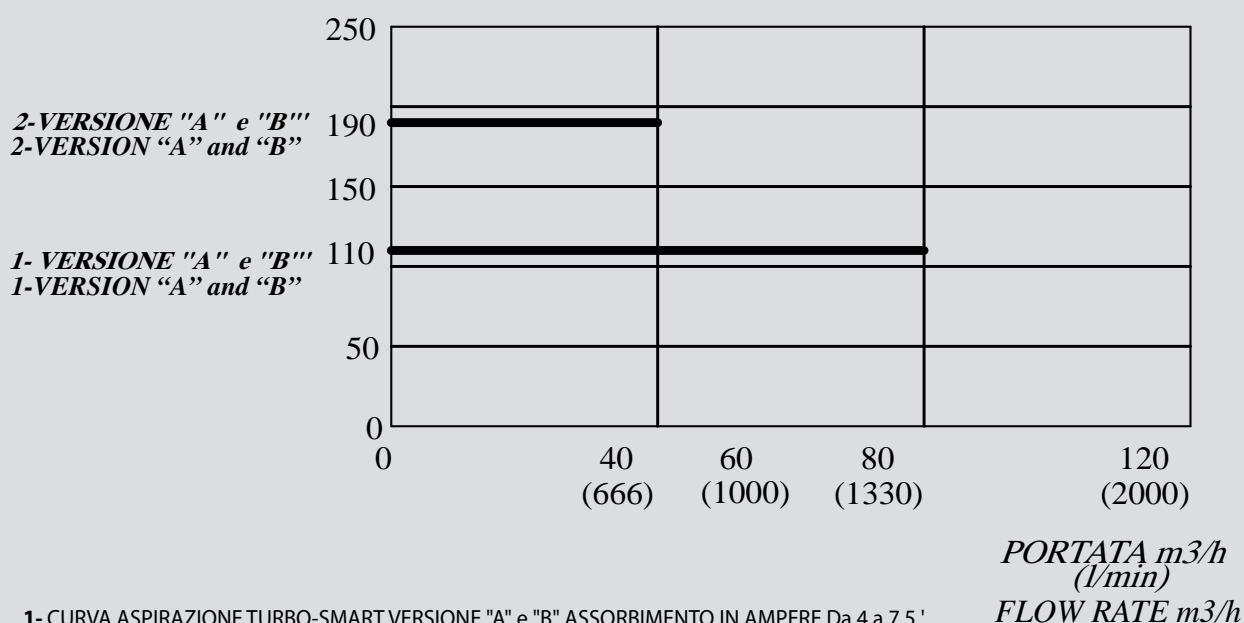

1 - CURVA ASPIRAZIONE TURBO-SMART VERSIONE "A" e "B" ASSORBIMENTO IN AMPERE Da 4 a 7,5'
 FREQUENZA (Hz) Da 85 a 110. PORTATA MAX PER POSTO LAVORO 20 m³/h
 PREVALENZA CONSIGLIATA PER INTERCETTATORE DI SPRUZZI.

1 - TURBO-SMART ASPIRATION CURVE VERSION "A" AND "B" ABSORPTION IN AMPERE from 4 to 7.5'
 CYCLE (Hz) From 85 to 110. MAX. FLOW RATE FOR EACH WORKING PLACE 20 m³/h
 MAX.HEAD SUGGESTED FOR SPRAY INTERCEPTOR.

2 - CURVA ASPIRAZIONE TURBO-SMART VERSIONE "A" e "B" ASSORBIMENTO IN AMPERE Da 5.5 a 7,5'
 FREQUENZA (Hz) Da 80 a 100. PORTATA MAX PER POSTO LAVORO 10 m³/h
 PREVALENZA CONSIGLIATA PER ASPIRAZIONE CHIRURGICA.

2 - TURBO-SMART ASPIRATION CURVE VERSION "A" AND "B" ABSORPTION IN AMPERE from 5.5 to 7.5'
 CYCLE (Hz) From 80 to 100. MAX. FLOW RATE FOR EACH WORKING PLACE 10 m³/h
 MAX.HEAD SUGGESTED FOR SURGICAL ASPIRATION

Fig. E

Draw.E

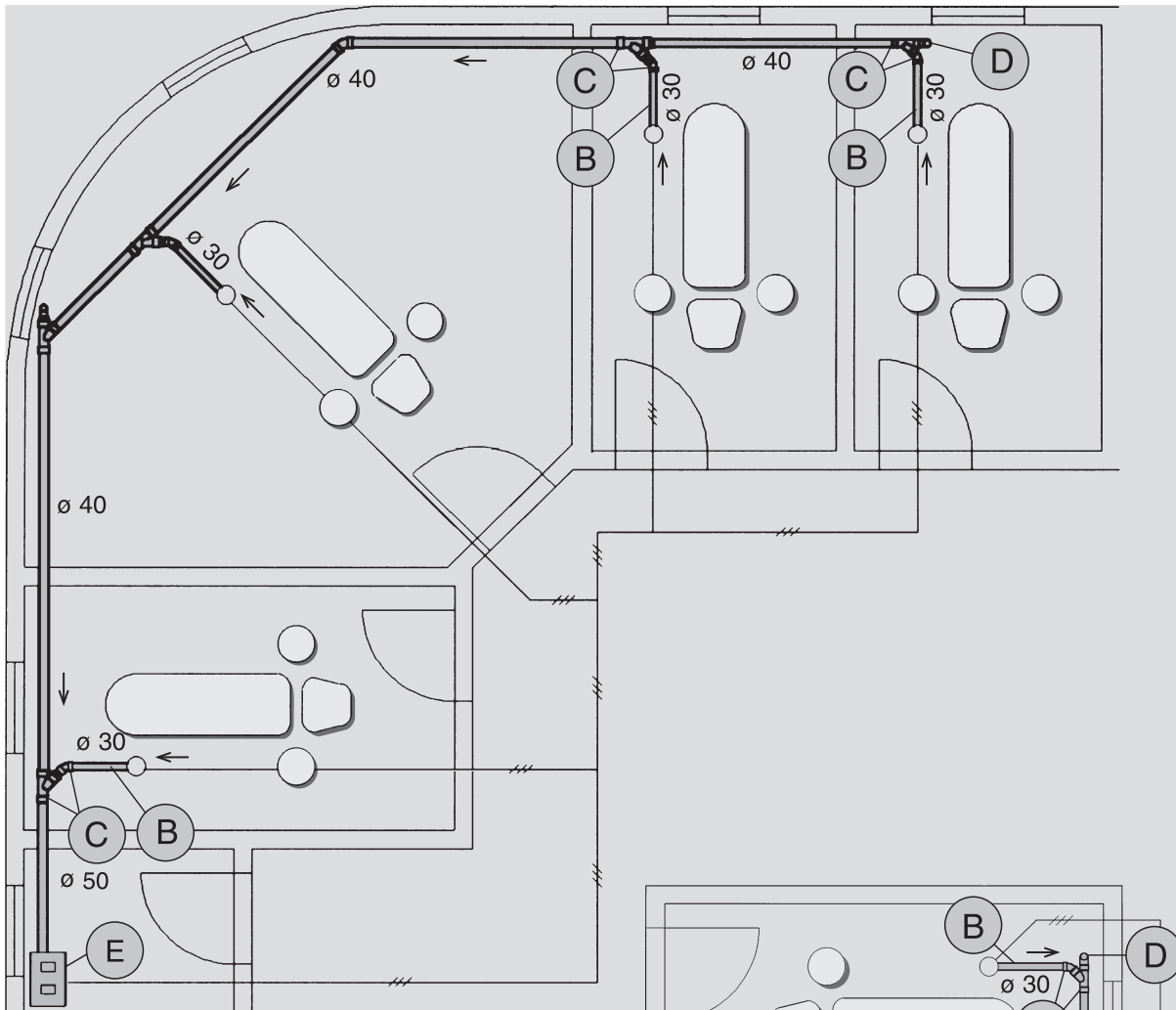

TURBO-SMART (versione "B")
TURBO-SMART (version "B")

Fig. F

Draw.F

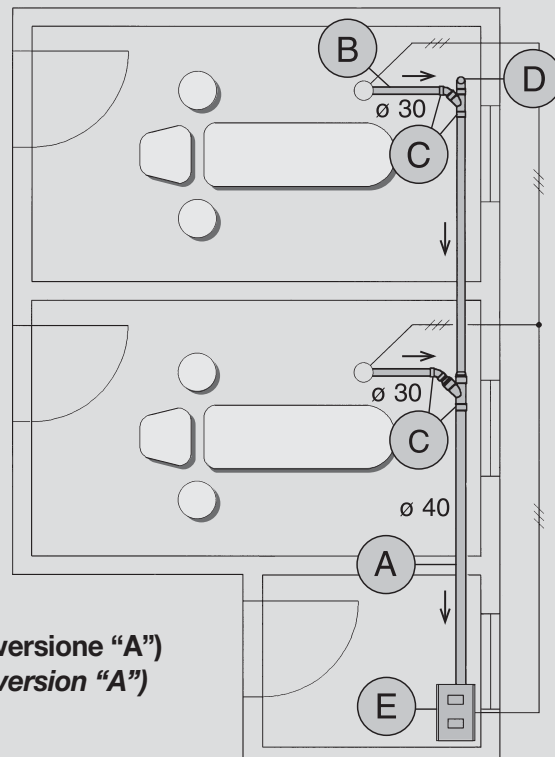

TURBO-SMART (versione "A")
TURBO-SMART (version "A")

- *ESPLOSO TURBO SMART*
- *SPLIT-UP DRAWING*

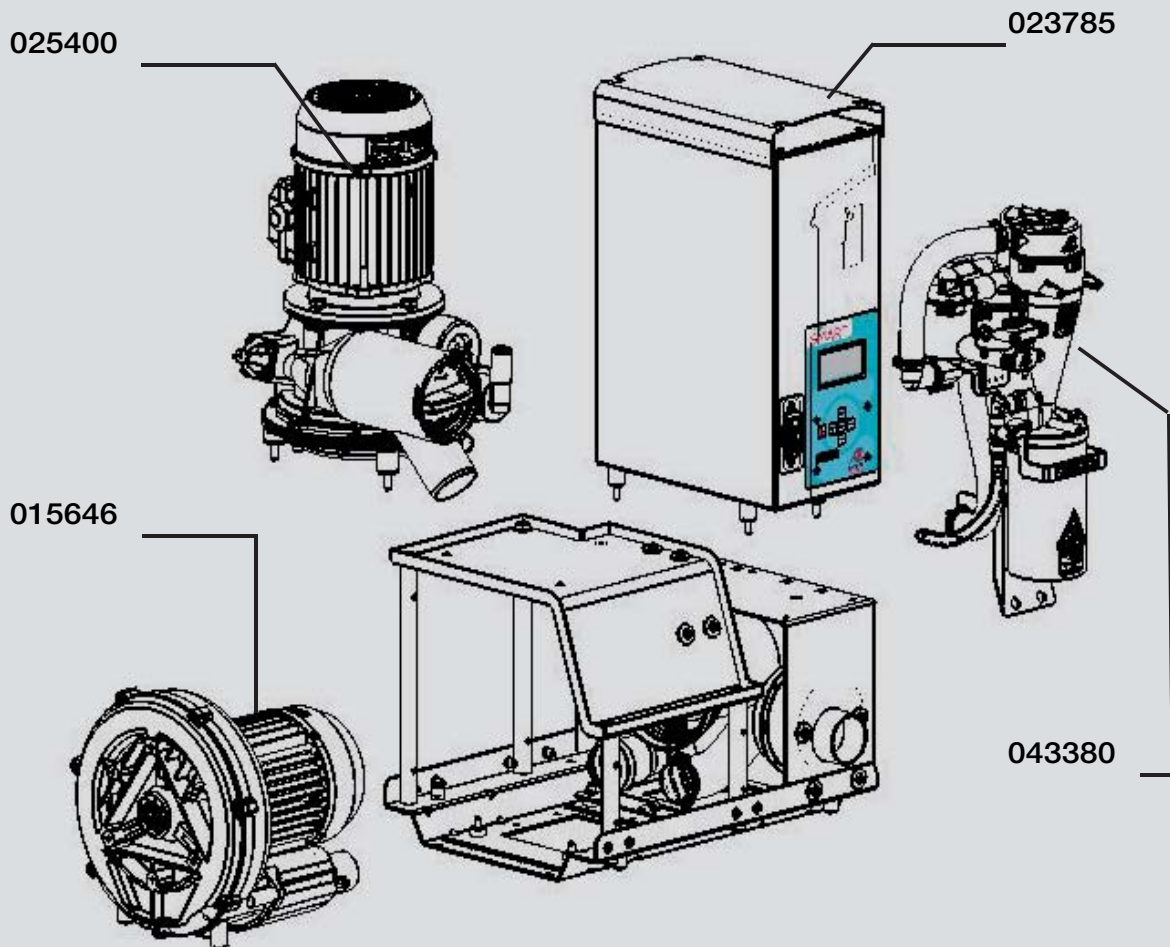

Fig. G

Draw. G

Cod. 023785	CENTRALINO ELETTRICO ELECTRIC CONTROL PANEL
Cod. 025400	SEPARATORE CENTRIFUGO CENTRIFUGAL SEPARATOR
Cod. 015646	SOFFIANTE BLOWER
Cod. 043380	IDROCICLONE HYDROCYCLONE

- *DIMENSIONI TURBO SMART*
- *TURBO SMART DIMENSION*

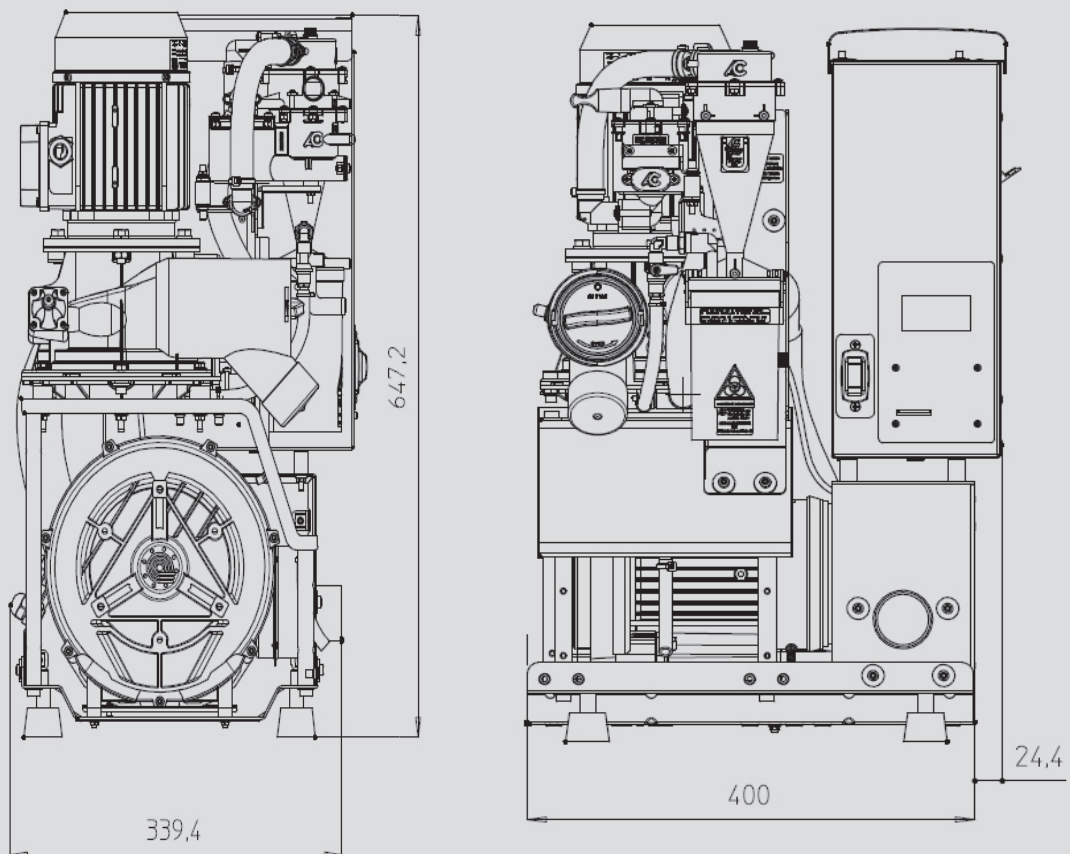

Fig. H

Draw.H

**HOW CAN WE DO
WE LEAD IN OUR FIELD,
YET WE COST LESS THAN
THE ALTERNATIVES?**

THIS IS HOW:

- **WE RESEARCH:** this lets us apply the latest technology in all of our products and solutions.
- **WE INCREASE PERFORMANCE:** electronic and information technology allow us to increase the performance and reliability of our products.
- **WE REDUCE COSTS:** less maintenance and energy costs mean on a cost-benefit analysis we are always the most economical.
- **WE REDUCE ENVIRONMENTAL IMPACT:** we save 50% of primary materials, and allow you to save between 30% and 50% of electrical consumption.



CATTANI

AIR TECHNOLOGY

6/A Via Natta. 43122 Parma, Italy
10°21'48" EST - 44°50'46" NORD

Ph. +39.0521.607604

Fax +39.0521.607628 (Sales Dept.)
Fax +39.0521.607855 (Purchasing Dept.)
Fax +39.0521.399966 (Accounting Dept.)

www.cattani.it - e-mail: info@cattani.it

Company with Quality System Certified according to
UNI EN ISO 9001:2008 - UNI EN ISO 13485:2012

